

TW METAL AND TILE

UNDERLAYMENT

MANUFACTURED IN JOPLIN, MO



WATERPROOFING PRODUCTS BEGIN TO AGE AS SOON AS THEY ARE EXPOSED TO NATURE. BUILDINGS EXPERIENCE AGING FACTORS DIFFERENTLY, SO IT IS DIFFICULT TO PREDICT HOW LONG WATERPROOFING PRODUCTS WILL LAST. THAT'S WHY TAMKO PROVIDES A LIMITED WARRANTY FOR MANY PRODUCTS, THAT INCLUDES A BINDING ARBITRATION CLAUSE AND OTHER TERMS AND CONDITIONS WHICH ARE INCORPORATED HEREIN BY REFERENCE. YOU MAY OBTAIN A COPY OF THE LIMITED WARRANTY AT TAMKO.COM OR BY CALLING 1-800-641-4691.

WARNING: USE OF POLYURETHANE FOAM INSULATION APPLIED DIRECTLY TO THE UNDERSIDE OF A ROOF DECK MAY CAUSE PREMATURE DEGRADATION OR FAILURE OF THIS ASPHALT ROOFING PRODUCT. WE ARE INVESTIGATING COMPATIBILITY OF POLYURETHANE FOAMS WITH OUR ASPHALT BUILDING PRODUCTS. CHEMICAL INCOMPATIBILITY, OFF-GASSING AFTER APPLICATION AND EXCESS HEAT DURING AND AFTER APPLICATION OF POLYURETHANE FOAMS MAY AFFECT THE PERFORMANCE OF ASPHALT AND MODIFIED ASPHALT BUILDING PRODUCTS AND METAL FASTENERS USED WITH THOSE PRODUCTS.



IMPORTANT SAFETY INFORMATION: Do not install until all appropriate safety precautions have been read and understood. [The TAMKO Safety Data Sheet \(SDS\) is available at tamko.com/sds.](https://www.tamko.com/sds) Always use appropriate fall protection equipment and wear appropriate personal protective equipment (PPE) when working with this product. Moisture, frost or debris will decrease the traction and can cause slippery conditions when walking on the product. **Applicator safety is of utmost importance.**

THIS TAMKO® PRODUCT IS COVERED BY A LIMITED WARRANTY AND ARBITRATION AGREEMENT, THE TERMS OF WHICH ARE PRINTED ON THE WRAPPER.

THESE ARE THE MANUFACTURER'S APPLICATION INSTRUCTIONS FOR TW METAL AND TILE UNDERLAYMENT. TAMKO BUILDING PRODUCTS, INC. ASSUMES NO RESPONSIBILITY FOR LEAKS OR OTHER DEFECTS RESULTING FROM FAILURE TO FOLLOW THE MANUFACTURER'S INSTRUCTIONS. FAILURE TO FOLLOW THESE INSTRUCTIONS WILL ADVERSELY AFFECT COVERAGE UNDER THE LIMITED WARRANTY AND ARBITRATION AGREEMENT. SEE THE LIMITED WARRANTY FOR DETAILS.

INFORMATION INCLUDED IN THESE APPLICATION INSTRUCTIONS WAS CURRENT AT THE TIME OF PRINTING. TO OBTAIN A COPY OF THE MOST CURRENT VERSION OF THESE APPLICATION INSTRUCTIONS, VISIT US ONLINE AT WWW.TAMKO.COM OR CALL US AT 1-800-641-4691.

TW METAL AND TILE UNDERLAYMENT

MANUFACTURED IN JOPLIN, MO

SAFETY PRECAUTION

Personal fall protection devices must always be used when applying TAMKO TW METAL AND TILE UNDERLAYMENT. Moisture, frost or debris will decrease the traction while walking on TAMKO TW METAL AND TILE UNDERLAYMENT. PLEASE EXERCISE CAUTION DURING INSTALLATION.

VENTILATION

TW Metal and Tile Underlayment should not be applied on roof decks over unventilated spaces or where spray foam insulation has been applied directly to the underside of the roof deck; doing so may result in premature degradation or product failure. A vapor retarding layer may result when TW Metal and Tile Underlayment is installed over an entire roof deck. Design of the entire roof system and the area immediately beneath the roof deck (e.g. attic, plenum, conditioned space) to properly address potential moisture and heat accumulation is the responsibility of a design professional (e.g. architect, engineer) and the building owner.

SURFACE PREPARATION

To begin, remove any dust, dirt, loose nails or other protrusions from the deck of new roofs. Remove all shingles, roofing felt, nails, or other existing roofing materials and debris from the deck of existing roofs. Sweep thoroughly to remove any dust and dirt. For best application, apply TAMKO® TW Metal and Tile Underlayment only in fair weather and when air, substrate, and membrane temperatures are above 40 °F. Priming is generally not required for surfaces that are smooth, clean, and dry. In any case where adhesion is found to be marginal, prime with TAMKO® TWP-1 or TWP-2 primers at the designated coverage rates. Priming is always required when adhering to concrete.

FOR ROOF DECKS

Apply TAMKO TW Metal and Tile Underlayment from low to high point in shingle fashion as shown below, so that laps will shed water. Overlap edge seams 4". End seams must be overlapped 6" and staggered. Where necessary, the membrane may be unrolled and cut into 10- to 15-foot lengths. Align the membrane on the lower edge of the roof. Remove the release film from the membrane then press the membrane into place. Roll lower edges firmly with a roofing seam roller; "Broom in" the installed membrane using an industrial flat broom or squeegee. Bear down on the installed membrane with the broom or squeegee to insure total, even adherence to the substrate. Care should be taken not to damage the surface when brooming.

FOR VALLEYS AND RIDGES

Where necessary, the membrane may be unrolled and cut into 4- to 6-foot lengths. Peel the release film and center sheet over valley or ridge. Drape and press sheet into place, working from the center of the valley or ridge outward in each direction. For valleys, apply the membrane starting at the lowest point and work upward. Overlap all sheets a minimum of 6 inches. The TW Metal and Tile Underlayment must be used on "closed valley" applications only. TW Metal and Tile Underlayment must not be left permanently exposed to the weather. It must be covered by roofing materials.

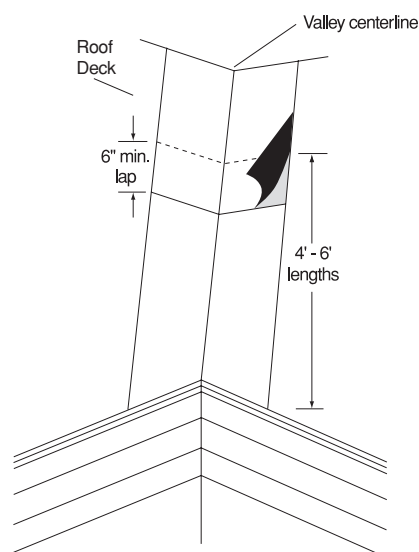

APPLICATION WITH ROLL LENGTH PARALLEL TO THE ROOF SLOPE

TAMKO TW Metal and Tile Underlayment may be applied with the long dimension of the roll running parallel to the roof slope in situations where the roof slope equals or exceeds 21 inches per foot. In these applications, side laps must be a minimum of 4" wide and formed so the smooth film selvage along one side of the roll is covered by the adjacent roll of TW Metal and Tile Underlayment. All side and end laps must be rolled with a roofing seam roller in addition to brooming the entire surface.

TW METAL AND TILE UNDERLAYMENT

MANUFACTURED IN JOPLIN, MO

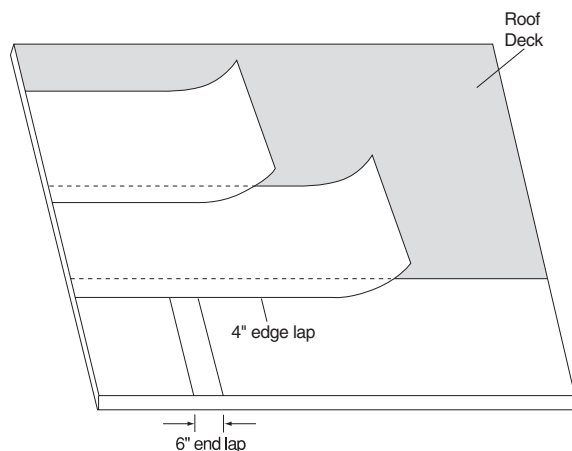

REPAIRING MINOR DAMAGE TO TW METAL AND TILE UNDERLAYMENT

Patch Repair: Minor damaged areas of TAMKO TW Metal and Tile Underlayment that are no larger than 4" by 4" in size can be repaired by installing a patch of TW Metal and Tile Underlayment extending a minimum of 12" beyond the damaged area on all sides.

End Lap Repair: Loose end laps no wider than 4" can be repaired by cutting and removing the loose material and applying a patch that extends 12" beyond the area on all sides.

Limitations that are stated in the Product Data Sheet available at tamko.com still apply when conducting repairs.

A Patch Repair or an End Lap Repair must begin with removal of dust, dirt and other materials that may interfere with adhesion from the area receiving the patch. Sweep the area to receive the patch with a stiff nylon bristle broom, making sure all loose material is removed from the area to receive the patch. Remove non-adhered, torn, or otherwise damaged membrane. The underlying substrate must not be damaged while performing a Patch Repair or an End Lap Repair.

Prime the entire area receiving the patch with TAMKO TWP-1 Quick Dry Primer at the recommended application rate to enhance adhesion (refer to the TWP-1 Quick Dry Primer Product Data Sheet). Allow the primer to cure prior to installation of the TW Metal and Tile Underlayment patch. Install the TW Metal and Tile Underlayment patch. Apply sufficient pressure using a broom or roofing seam roller to promote adhesion to the underlying material. Seal the edges of the patch by applying a bead of compatible polyurethane sealant; smooth the bead with a trowel. Select a sealant suitable for use with rubberized asphalt per the sealant manufacturer's written application instructions.

IMPORTANT:

Tiles can slide during roof loading and until properly fastened. In order to protect TW Metal and Tile Underlayment from damage, care must be taken to insure stability of stacked tiles. Fasteners and batten strips must be used when installing tiles over TW Metal and Tile. TAMKO requires mechanical fastening of every tile regardless of the slope. These are TAMKO's minimum requirements. State and local registrations may contain additional requirements.