

TAMKO® TW MOISTURE WRAP

Above Grade Moisture / Air Barrier Membrane

APPLICATION INSTRUCTIONS

PREPARATION

All surfaces must be dry and clean. Dirt, dust and any other foreign matter must be removed. TW MOISTURE WRAP must be applied when air, substrate, and membrane temperatures are above 40 degrees F.

Acceptable surfaces are cast-in-place concrete, pre-cast concrete, concrete masonry blocks, exterior gypsum sheathing, plywood, OSB, DensGlass®, DensGlass Gold®, felt-faced and foil-faced polyisocyanurate foam insulation, EPS / XPS, ICF, wood, vinyl or metal surfaces. Concrete must be allowed to cure for a minimum of 7 days prior to application of TW MOISTURE WRAP.

PRIMING

Priming is generally not required for most substrates provided they are clean and dry. However, on concrete, masonry, DensGlass® and DensGlass Gold® as well as any additional surfaces where adhesion is found to be marginal, prime the surface receiving flashing with the appropriate primer, TWP-1 Quick Dry Primer** or TWP-2 Water-Based Primer at the designated coverage rate according to primer application instructions for specified weather conditions. DO NOT USE TWP-1 Quick Dry Primer on EPS / XPS or ICF surfaces.

FASTENING

Mechanical fastening using a smooth-shank fastener is recommended in situations where adhesion is found to be marginal after priming. Stapling individual pieces of flashing around the entire perimeter of the flashing 18" on center will maintain attachment to the substrate.

GENERAL APPLICATION

Unroll TW MOISTURE WRAP and cut to the desired length. Begin by removing approximately 12 inches of the release film and center the membrane over the area to be covered. Firmly press or roll the membrane against the substrate and continue pulling the release film off while smoothing the membrane into place.

SPECIFIC APPLICATION

The remaining portion of these application instructions addresses specific applications of the TW MOISTURE WRAP membrane for full coverage envelope applications and window and door perimeter applications.

Be sure to read through these instructions to first identify the application method which is specific to your installation before you begin the application process.

Failure to properly apply TAMKO TW Moisture Wrap according to the Application Instructions may affect coverage under the applicable 5-year limited warranty.

FULL COVERAGE ENVELOPE APPLICATIONS

In full coverage envelope application, TW MOISTURE WRAP should be tightly sealed into roofing and below-grade waterproofing systems and structural perimeter flashings to retain the integrity of the air barrier throughout the entire structure. Note that in full coverage envelope applications, the dew point must be engineered to the outside of the building. Side laps must be a minimum of 2 inches and end laps should be 4 inches. All terminations must be sealed with TWM-1 Mastic.

For DensGlass and DensGlass Gold sheathing and OSB, all air and vapor barrier applications are to be done vertically with membrane no longer than 6 feet. Material must be broomed in using a stiff, hand-held broom.

** WARNINGS AND HAZARDS

TWP-1 contains combustible solvents. Avoid exposure to sparks, open flame, heat, and other forms of ignition. Use in well ventilated areas. Avoid breathing vapors. Refer to MSDS for detailed product information and warnings.

CAUTION: The National Institute for Occupational Safety and Health has concluded that the fumes of heated roofing asphalt are a potential occupational carcinogen. The physical nature of this product may help limit any inhalation or dermal hazard during application and/or removal. However, physical forces such as sawing, grinding or drilling during demolition work and heating or burning may increase the inhalation or dermal exposure hazard of this product. Take precautions to prevent breathing and contact with skin.



TAMKO® TW MOISTURE WRAP

Above Grade Moisture / Air Barrier Membrane

WINDOW FLASHING APPLICATION

This section is for application of TW Moisture Wrap to protect against moisture and air leaks around window perimeters.

Before you begin - Determine if window will be installed prior to or after installation of the Water Resistive Barrier (WRB) and follow the appropriate Method (Method A or A1) dependant on the WRB installation plan. Be sure to follow all preparation, priming, fastening, and general application procedures as stated previously in these instructions together with the specific window installation method.

METHOD A: APPLIED PRIOR TO WATER RESISTIVE BARRIER (WRB)

(Self-Adhesive Flashing for windows with integral flanges; flashing applied prior to Water Resistive Barrier)

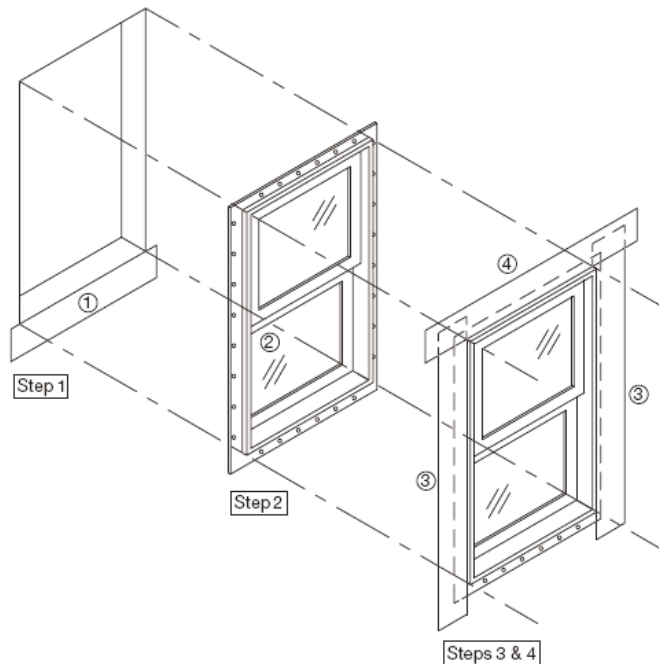

Figure 1: Window installation detail for windows with integral flanges and flashing installed prior to WRB

1. Sill Flashing - Flash the bottom of the sill by cutting the flashing the width of the rough opening plus 2 times the flashing width. Partially remove the release liner so that the release liner remains in place on the lower two inches of the flashing. Center the flashing horizontally relative to the rough opening. Align the edge of the flashing with the adhesive exposed with the bottom of the rough window opening and firmly press the flashing into place. Tape the lower edge of the flashing to prevent wind damage until WRB installation. Do not adhere the bottom 2" of the flashing at this time (See step 5 below).

2. Install Window - Install the window in the rough opening following the window manufacturer's instructions.

3. Jamb Flashing - Confirm window flange is clean and dirt-free by wiping the flange with a clean rag. Cut two jamb flashings the length of the rough opening plus 2 times the width of the flashing minus 1". Align the end of one jamb flashing even with the bottom of the sill flashing. Remove the release liner and press the flashing firmly into place, fully covering the flange along one side of the window. Repeat procedure for other side of window. The ends of the sill flashing must not protrude beyond the edges of the jamb flashings. If the sill flashing protrudes beyond the edges of the overlying jamb flashings, remove and discard the protruding portion of the sill flashing.

4. Head Flashing - Confirm window flange is clean and dirt-free by wiping the flange with a clean rag. Cut the head flashing the width of the rough opening plus 2 times the width of the flashing plus 2". Center the head flashing over the rough opening. Remove the release liner and press the flashing firmly into place. Flashing must be flush against the top of the window, fully covering the window flange and extending 1" beyond the jamb flashing on each side.

5. WRB Installation - Install the WRB in accordance with the WRB manufacturer's instructions. Tuck the WRB under the unadhered portion of the sill flashing, remove the remainder of the release liner from the sill flashing, and adhere the sill flashing to the WRB by firmly pressing the flashing into place.

TAMKO® TW MOISTURE WRAP

Above Grade Moisture / Air Barrier Membrane

WINDOW FLASHING APPLICATION (continued)

METHOD A1: APPLIED AFTER WATER RESISTIVE BARRIER (WRB)

(Self-Adhesive Flashing for windows with integral flanges; flashing applied after Water Resistive Barrier)

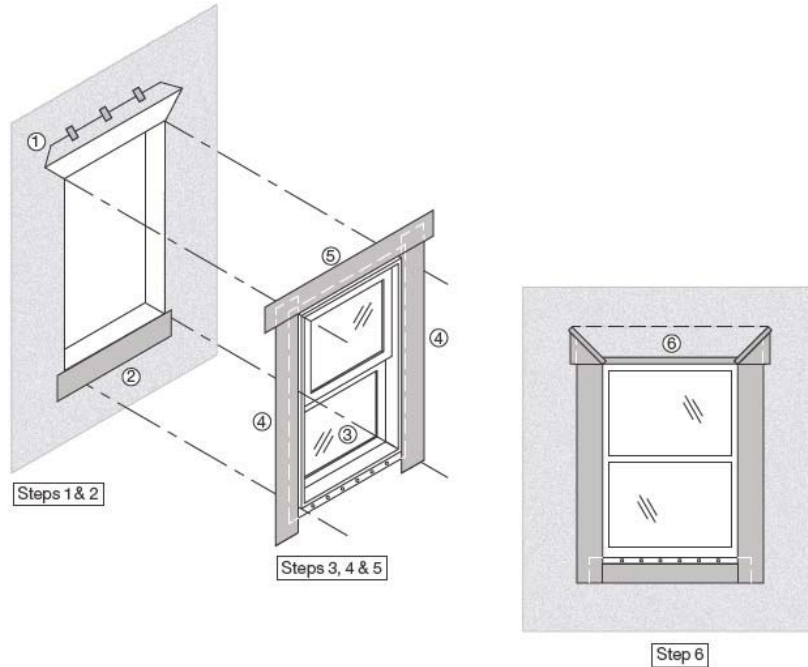

Figure 2: Window installation detail for windows with integral flanges and flashing installed after WRB

1. Preparation of Installed WRB - If the WRB covers all or part of the rough opening, cut the WRB even with the edge of the rough opening and discard the portion of the WRB that was removed from the rough opening. At the head of window opening, cut the WRB at a 45° angle at each corner according to the diagram shown above. Carefully lift and tape the corners to place WRB out of the way for remaining application steps.

2. Sill Flashing - Flash the bottom of the sill by cutting the flashing the width of the rough opening plus 2 times the flashing width minus 2". Remove the release liner. Center the flashing horizontally relative to the rough opening and align the top edge of the flashing with the bottom of the rough window opening. Firmly press the flashing into place.

3. Install Window - Install the window in the rough opening following the window manufacturer's instructions.

4. Jamb Flashing - Confirm window flange is clean and dirt-free by wiping the flange with a clean rag. Cut two jamb flashings the length of the rough opening plus 2 times the width of the flashing minus 1". Align the end of one jamb flashing even with the bottom of the sill flashing. Remove the release liner and press the flashing firmly into place, fully covering the flange along one side of the window. Repeat procedure for other side of window.

5. Head Flashing - Confirm window flange is clean and dirt-free by wiping the flange with a clean rag. Cut the head flashing the width of the rough opening plus 2 times the width of the flashing plus 2". Center the head flashing over the rough opening. Remove the release liner and press the flashing firmly into place. Flashing must be flush against the top of the window, fully covering the window flange and extending 1" beyond the jamb flashing on each side.

6. Complete the Head Flashing By Taping the WRB - Untape the WRB and lower over the flashing. Apply new pieces of sheathing tape diagonally over the cut WRB, adhering it to the flashing. Press firmly into place.

TAMKO® TW MOISTURE WRAP

Above Grade Moisture / Air Barrier Membrane

DOOR FLASHING APPLICATION

This section is for application of TW Moisture Wrap to protect against moisture and air leaks around door perimeters.

Before you begin - Determine if door will be installed prior to or after installation of the Water Resistant Barrier (WRB) and follow the appropriate Method (Method A or A1) dependant on the WRB installation plan. Be sure to follow all preparation, priming, fastening, and general application procedures as stated previously in these instructions together with the specific door installation method.

METHOD A: APPLIED PRIOR TO WATER RESISTIVE BARRIER (WRB)

(Self-Adhesive Flashing for doors with integral flanges; flashing applied prior to Water Resistant Barrier)

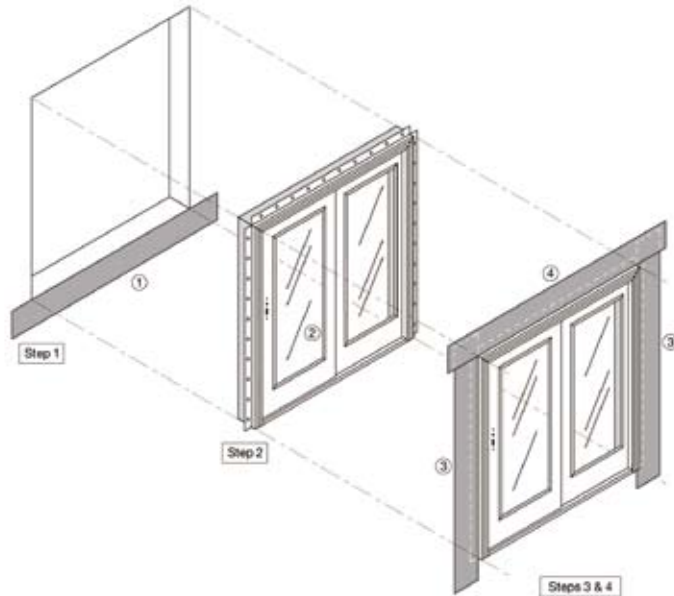

Figure 3: Door installation detail for doors with integral flanges and flashing installed prior to WRB

1. Sill Flashing - If the door will be installed without a mounting flange at the sill, prepare the sill to receive the door in accordance with the door manufacturer's installation instructions and proceed to step 2. If the door will be installed with a sill mounting flange, flash the bottom of the sill by cutting the flashing the width of the rough opening plus 2 times the flashing width. Partially remove the release liner so that the release liner remains in place on the lower two inches of the flashing. Center the flashing horizontally relative to the rough opening. Align the edge of the flashing with the adhesive exposed with the bottom of the rough window opening and firmly press the flashing into place. Tape the lower edge of the flashing to prevent wind damage until WRB installation. Do not adhere the bottom 2" of the flashing at this time (See step 5 below).

2. Install Door - Install the door in the rough opening following the door manufacturer's instructions.

3. Jamb Flashing - Confirm door flange is clean and dirt-free by wiping the flange with a clean rag. If the door is installed without a mounting flange at the sill, cut two jamb flashings long enough to extend below the rough opening sill up to the full width of the flashing material and above the rough opening head the width of the flashing minus 1". Align the end of one jamb flashing so it is positioned 1" below where the top of the head flashing will be located, remove the release liner and press the flashing firmly into place, fully covering the flange along one side of the door. Repeat procedure for other side of door.

If the door is installed with a sill mounting flange, cut two jamb flashings the length of the rough opening plus 2 times the width of the flashing minus 1". Align the end of one jamb flashing even with the bottom of the sill flashing. Remove the release liner and press the flashing firmly into place, fully covering the flange along one side of the door. Repeat procedure for other side of door. The ends of the sill flashing must not protrude beyond the edges of the jamb flashings. If the sill flashing protrudes beyond the edges of the overlying jamb flashings, remove and discard the protruding portion of the sill flashing.

4. Head Flashing - Confirm door flange is clean and dirt-free by wiping the flange with a clean rag. Cut the head flashing the width of the rough opening plus 2 times the width of the flashing plus 2". Center the head flashing over the rough opening. Remove the release liner and press the flashing firmly into place. Flashing must be flush against the top of the door, fully covering the door flange and extending 1" beyond the jamb flashing on each side.

5. WRB Installation - Install the WRB in accordance with the WRB manufacturer's instructions. If the door is installed with a sill mounting flange, tuck the WRB under the unadhered portion of the sill flashing, remove the release liner from the sill flashing, and adhere the sill flashing to the WRB by firmly pressing the flashing into place.

TAMKO® TW MOISTURE WRAP

Above Grade Moisture / Air Barrier Membrane

DOOR FLASHING APPLICATION (continued)

METHOD A1: APPLIED AFTER WATER RESISTIVE BARRIER (WRB)

(Self-Adhesive Flashing for doors with integral flanges; flashing applied after Water Resistive Barrier)

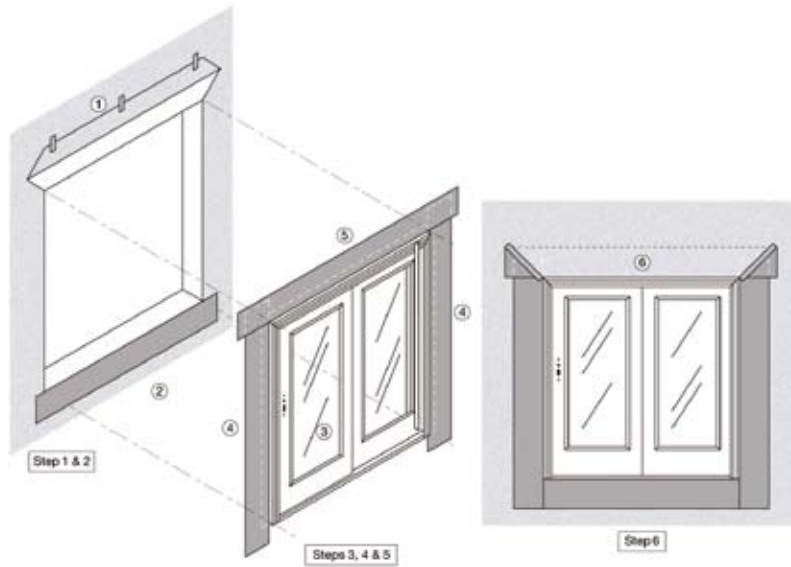

Figure 4: Door installation detail for doors with integral flanges and flashing installed after WRB

1. Preparation of Installed WRB - If the WRB covers all or part of the rough opening, cut the WRB even with the edge of the rough opening and discard the portion of the WRB that was removed from the rough opening. At the head of door opening, cut the WRB at a 45° angle at each corner according to the diagram shown above. Carefully lift and temporarily tape up the corners to place WRB out of the way for remaining application steps.

2. Sill Flashing - If the door will be installed without a mounting flange at the sill, prepare the sill to receive the door in accordance with the door manufacturer's installation instructions and proceed to step 3. If the door will be installed with a sill mounting flange, flash the bottom of the sill by cutting the flashing the width of the rough opening plus 2 times the flashing width minus 2". Remove the release liner. Center the flashing horizontally relative to the rough opening and align the top edge of the flashing with the bottom of the rough door opening. Firmly press the flashing into place.

3. Install Door - Install the door in the rough opening following the door manufacturer's instructions.

4. Jamb Flashing - Confirm door flange is clean and dirt-free by wiping the flange with a clean rag. If the door is installed without a mounting flange at the sill, cut two jamb flashings long enough to extend below the rough opening sill up to the full width of the flashing material and above the rough opening head the width of the flashing minus 1". Align the end of one jamb flashing so it is positioned 1" below where the top of the head flashing will be located, remove the release liner and press the flashing firmly into place, fully covering the flange along one side of the door. Repeat procedure for other side of door.

If the door is installed with a sill mounting flange, cut two jamb flashings the length of the rough opening plus two times the width of the flashing minus 1". Align the end of one jamb flashing even with the bottom of the sill flashing. Remove the release liner and press the flashing firmly into place, fully covering the flange along one side of the door. Repeat procedure for other side of door.

5. Head Flashing - Confirm door flange is clean and dirt-free by wiping the flange with a clean rag. Cut the head flashing the width of the rough opening plus 2 times the width of the flashing plus 2". Center the head flashing over the rough opening. Remove the release liner and press the flashing firmly into place. Flashing must be flush against the top of the door, fully covering the door flange and extending 1" beyond the jamb flashing on each side.

6. Complete the Head Flashing By Taping the WRB - Untape the WRB and lower over the flashing. Apply new pieces of sheathing tape diagonally over the cut WRB, adhering it to the flashing. Press firmly into place.

Information included in this product data sheet was current at time of printing. To obtain a copy of the most current version of this product data sheet, visit us online at tamko.com or call us at 800-641-4691.

This product is covered by a 5-year limited warranty. For information regarding or a copy of TAMKO's limited warranty, contact your local TAMKO representative, visit us online at tamko.com, or call us at 800-641-4691.

TAMKO® TW MOISTURE WRAP

Above Grade Moisture / Air Barrier Membrane

tamko.com

Corporate

Central District

Northeast District

Southeast District

Southwest District

Western District

220 West 4th Street, Joplin, Missouri 64801

220 West 4th Street, Joplin, Missouri 64801

4500 Tamko Drive, Frederick, Maryland 21701

2300 35th Street, Tuscaloosa, Alabama 35401

7910 South Central Expressway, Dallas, Texas 75216

5300 East 43rd Avenue, Denver, Colorado 80216

800-641-4691

800-641-4691

800-368-2055

800-228-2656

800-443-1834

800-530-8868



©2012 TAMKO Building Products, Inc. DensGlass® and DensGlass Gold® are registered trademarks of Georgia-Pacific Corporation. TAMKO® and TW Flash-N-Wrap® are registered trademarks of TAMKO Building Products, Inc.

TAMKO® TW MOISTURE WRAP

Above Grade Moisture / Air Barrier Membrane

PRODUCT DATA

DESCRIPTION

TAMKO® TW MOISTURE WRAP is a flexible 40 mil self-adhering rubberized asphalt sheet membrane with a clear polymer film on the surface film and a removable treated release film on the adhesive side.

USES

TAMKO TW MOISTURE WRAP is designed for use as an above grade moisture / air barrier and is suitable for application in cavity wall construction, sealing window and door perimeters, sealing of wall joints, corners, and other terminations. TW MOISTURE WRAP is suitable for application to concrete, block, exterior gypsum sheathing or wood surfaces. TW MOISTURE WRAP may be applied horizontally, and may also be installed vertically when applied over the full surface area.



ADVANTAGES

- Flexible SBS modified asphalt and polymer film surfacing provides excellent protection from moisture or air penetration.
- Treated release film for easier installation and handling.
- High temperature resistance up to 245°F.
- Adheres to cast-in-place concrete, pre-cast concrete, concrete masonry block, exterior gypsum sheathing, plywood, OSB, DensGlass®, DensGlass Gold®, EPS insulation, felt and foil-faced polyisocyanurate foam insulation, wood, vinyl or metal surfaces.
- Available in factory pre-cut widths of 4", 6", 9", 12", 18", 24", 36" and 39-3/8" rolls.
- Individually wrapped factory pre-cut widths with point-of-purchase (POP) labels are available in 4", 6" and 9" roll sizes.
- ICC-ES ESR-2260 and ESR-2882.

LIMITATIONS

- Membrane or primer must not be applied to damp, frosty or contaminated surfaces.
- Membrane must not be left exposed to sunlight for more than 30 days. For applications requiring longer exposure before covering, use TW Window & Door Flash, TW Flash-N-Wrap® 25, or TW Flash-N-Wrap® 40. TAMKO recommends covering this material as soon as possible for ultimate product performance as severe weather to exposed product may affect performance.
- Membrane must not come into contact with products containing coal-tar pitch.
- Membrane must be applied when air, substrate and membrane temperatures are above 40° F.
- Not designed for use in ponding areas.

PRODUCT DATA*

Surfacing	Polymer		
Asphalt Modifier	SBS		
Product Thickness	40 mil		
Roll Width	Roll Size	Coverage per Ctn.	Rolls per ctn.
4"	4" x 75'	225 sq. ft.	9
6"	6" x 75'	225 sq. ft.	6
9"	9" x 75'	225 sq. ft.	4
12"	12" x 75'	225 sq. ft.	3
18"	18" x 75'	225 sq. ft.	2
24"	24" x 75'	150 sq. ft.	1
36"	36" x 75'	225 sq. ft.	1
39-3/8"	39-3/8" x 75'	246 sq. ft.	1 roll / wrapper
Ind Wrap 4"	4" x 75'	225 sq. ft.	9
Ind Wrap 6"	6" x 75'	225 sq. ft.	6
Ind Wrap 9"	9" x 75'	225 sq. ft.	4

*All values stated as nominal at time of manufacture.

TAMKO® TW MOISTURE WRAP

Above Grade Moisture / Air Barrier Membrane

TYPICAL PHYSICAL PROPERTIES

Property	Test Method	Typical Value
Tensile Strength (psi)	ASTM D 1970	
MD		994
CD		771
Tensile Strength After UV Exposure (psi)		
MD	ASTM D 1970	573
CD		467
Peel Adhesion (lb/in.)	ASTM D 3330	
Plywood (APA Exposure 1)		6.5
OSB (APA Exposure 1)		5.4
Aluminum		13.3
Vinyl		6.0
Galvanized Metal		9.2
Masonry Block (Unprimed)		7.3
Concrete (Unprimed)		9.3
DensGlass (Unprimed)		4.6
Exterior Gypsum Sheathing (Unprimed)		Exceeds strength of substrate
EPS (Representative of ICF)		Exceeds strength of substrate
Peel Adhesion to Aluminum (lb/in)	ASTM D 3330	
After Accelerated UV Aging (28 days)		2.1
After Elevated Temperature Exposure		19.5
After Thermal Cycling		15.2
Peel Adhesion After Water Immersion (lb/in)	AAMA 711-05	17.1
Resistance to Peel from Flashing Facing	AAMA 711-05	Pass
Water Resistance		
As Received	AATCC 127	Pass
After Accelerated Aging	AATCC 127	Pass
Water Penetration Around Nails	ASTM E 331/E 547	
Tested at 7.8 psf and 28.9 psf		
As Received		Pass
After thermal exposure (25 cycles)		Pass
Pliability 0 F (Pass/Fail)	ASTM D 1970	Pass
Water Penetration Resistance of Assemblies Constructed per TAMKO Method A or A1 (Evaluated at 12 psf for 120 minutes)	ASTM E 331	Pass
Permeance	ASTM E 96 (BW)	.05 perms (max)
Air Permeance ($\Delta P = 75$ Pa)	ASTM E 2178	<0.0001 L/s-m ² (<0.0000 CFM/ft ²)

tamko.com

Corporate	220 West 4th Street, Joplin, Missouri 64801	800-641-4691
Central District	220 West 4th Street, Joplin, Missouri 64801	800-641-4691
Northeast District	4500 Tamko Drive, Frederick, Maryland 21701	800-368-2055
Southeast District	2300 35th Street, Tuscaloosa, Alabama 35401	800-228-2656
Southwest District	7910 South Central Expressway, Dallas, Texas 75216	800-443-1834
Western District	5300 East 43rd Avenue, Denver, Colorado 80216	800-530-8868



©2012 TAMKO Building Products, Inc. DensGlass® and DensGlass Gold® are registered trademarks of Georgia-Pacific Corporation. TAMKO® and Flash-N-Wrap® are registered trademarks of TAMKO Building Products, Inc.