

IMPORTANT EVERGRAIN PRODUCT INFORMATION

- Make safety of the workplace the prime consideration. Always wear the proper protective clothing and safety equipment, and do not attempt to lift or carry more railing than you can safely handle at one time.
- Like wood, color variation of EverGrain materials will occur. Lay out and view all materials before cutting or fastening to check for consistency in color.
- Discuss any desired material changes, including color matching, with the supplier prior to cutting or fastening the railing to the structure.
- The color of EverGrain material will usually weather to a lighter shade within the first 12 weeks of exposure to the environment. Color selection may vary across profiles.
- EverGrain railing must be installed in accordance with the installation instructions. Deviations from these instructions may result in unsatisfactory performance and may exclude coverage of your material under the limited warranty.

KITS/COMPONENTS

6-Foot Designer Rail Kit Includes:

- 1 - Designer Hand Rail (Actual length 70")
- 2 - Designer Pre-Drilled Universal Rails (Actual length 70")
- 1 - 8 1/2" Crush Block (Requires cutting into two 4" blocks)
- 1 - Rail Hardware Pack

6-Foot Designer Stair Rail Kit Includes:

- 1 - Designer Hand Rail (Actual length 74")
- 2 - Designer Universal Rails (Actual length 74")
- 1 - 8 1/2" Crush Block (Requires cutting to size)
- 1 - Stair Rail Hardware Pack

Baluster Kit Includes: (Pre-sized for 36" or 42" railing heights)

- 13 - Pre-Drilled Oval Balusters (Patent Pending) (Actual lengths 27" or 33")
- 1 - Baluster Hardware Pack

Post Sleeve Kits Include: (Your choice of 38", 48" or 116")

- 1 - 4" x 4" x 38" Post Sleeve
- 1 - Designer Post Cap
- 1 - Designer Post Ring

- 1 - 4" x 4" x 48" Post Sleeve
- 1 - Designer Post Cap
- 1 - Designer Post Ring

- 1 - 4" x 4" x 116" Post Sleeve (Cap and Ring not included)

NOTE: You will need 1 rail kit, 1 baluster kit, and 2 post sleeves to complete one 6 ft. section of railing (1-Post Cap & 1-Post Ring is included in both 38" & 48" post sleeve kits). With Designer railing, you are able to mix and match between 7 different colors that are sure to complement your building project.

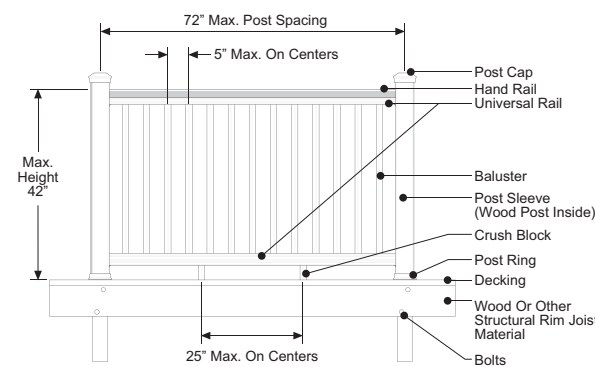

TOOLS NEEDED



miter box saw



tape measure



level



drill

- 1/8" drill bit
- Phillips head bit
- #2 drive square head

INSTALLATION

It is the responsibility of the installer to meet all building code and safety requirements and to obtain all required building permits. These instructions are only a guide and may not address every circumstance. These application instructions were current at the time of printing. To obtain a copy of the most current version of the application instructions, visit us online at www.evergrain.com or call us at 800-641-4691.

Designer Straight Rail Instructions

1. Install and prepare all mounting surfaces and posts to which your new Designer Railing will be installed. Wood posts must be spaced at a maximum of 72" on centers. Do not notch post. For best appearance, cover your 4" x 4" wooden posts with EverGrain post sleeves. **NOTE: Due to various lumber sizes, planing of the wooden posts may be required.**
2. Before installing the EverGrain post sleeve, use a level to ensure that all wood posts are vertically plumb.
3. Measure and cut each post sleeve to the correct height for your railing system. **(Figure 1)**
 - 36" rail height = 38" post sleeve
 - 42" rail height = 44" post sleeve
4. Place the post ring onto the bottom of the post sleeve, and then slide the post sleeve over the wooden post. The post sleeve must rest flush on the deck surface. **NOTE: Do not force the post sleeve over the post. Due to various lumber sizes, planing of the wooden posts may be required.**
5. Measure up from the deck surface 33" for a 36" railing height or 39" for a 42" high railing and mark. Place top of bracket at marked height and pre-drill through the bottom two screw holes of the rail bracket into the post sleeve. Connect the top two EverGrain brackets to the posts with the 2 provided #10 x 2 1/2" screws. **(Figure 2)**
6. Lay the bottom universal rail beside the post sleeves with the pre-drilled holes facing upward, making sure the single leg is facing the outer perimeter as shown in Figure 3. The rails should extend past the post sleeves on each side, making sure your rail opening does not exceed the rail length. Be sure to place the first pre-drilled hole on each end of the rail the same distance from the post sleeve. **NOTE: Arrange the universal rail so you do not end at a post sleeve with a partial baluster position.** Mark both ends of the rail where they cross the post sleeve and cut to length. Transfer your marks to the top universal rail and hand rail and cut to length. **(Figure 3)**
7. Locate the 8 1/2" oval crush block in your Designer Rail kit. Cut two 4" crush blocks to be positioned on the underneath side of the bottom universal rail.
8. Position all railing components out on a flat work surface, aligning the pre-drilled holes on the universal rails to the pre-cut, pre-drilled balusters. **NOTE: Maximum baluster spacing must not exceed 5" on center, so that the space between balusters will not exceed 4". (Figure 4)**
9. Locate the two remaining rail brackets. Pre-drill through the top three holes of the bracket into the ends of the bottom universal rails and attach with the 3 provided #10 x 1" screws. **(Figure 5)**
10. Pre-drill and attach the crush blocks by driving a provided #8 x 3" screw, or a #8 x 3" color coordinating screw (not provided) down through the top of the bottom universal rail. The crush blocks must be positioned on the underneath side of the bottom universal rail at a maximum of 25" on centers.
11. Remove the baluster hardware pack from the baluster kit and begin attaching balusters to the top universal rail using the provided #8 x 3" screws. Repeat for the bottom universal rail. **Note: Do not overdrive screws into the balusters. (Figure 6)**
12. Slide the handrail over the top universal rail. **(Figure 7)**
13. Raise the rail and place it between the posts by setting it on the crush blocks and the two top EverGrain brackets. **(Figure 8)**
14. Center the bottom of the rail section on the post sleeve. Pre-drill through the bottom two holes of the bracket and attach both bottom brackets to the post sleeve with the 2 provided #10 x 2 1/2" rail bracket screws. **Note: A bit extension may be necessary to drive screws. (Figure 9)**
15. Pre-drill and attach both top rail brackets to the underside of the universal rail. **Note: A bit extension may be necessary to drive screws. (Figure 10)**
16. Attach the post cap using adhesive.

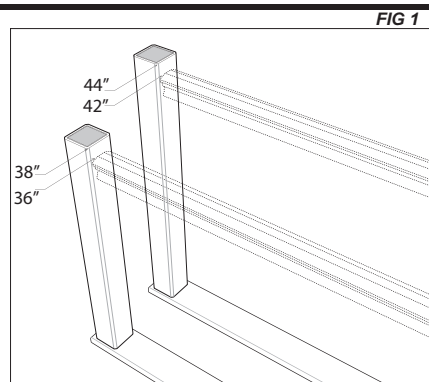

FIG 1

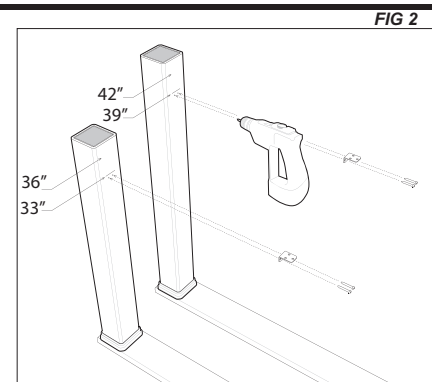

FIG 2

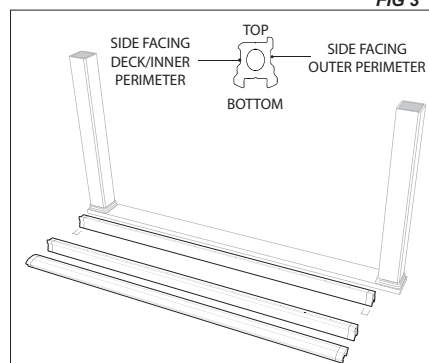

FIG 3

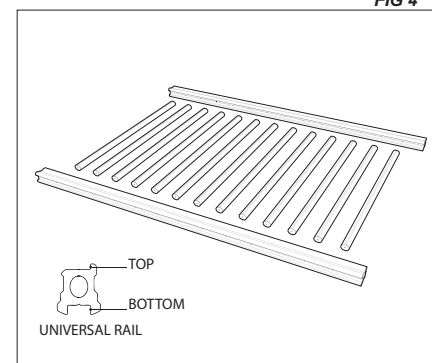

FIG 4

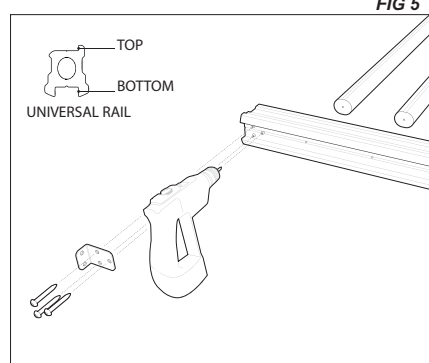

FIG 5

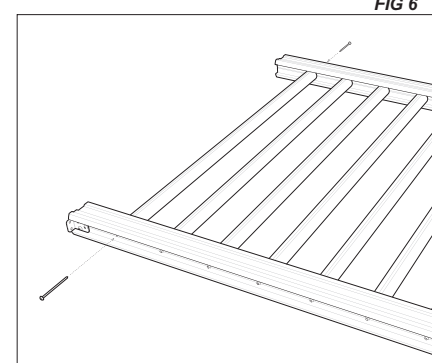

FIG 6

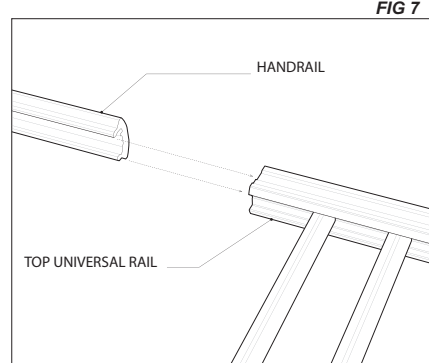

FIG 7

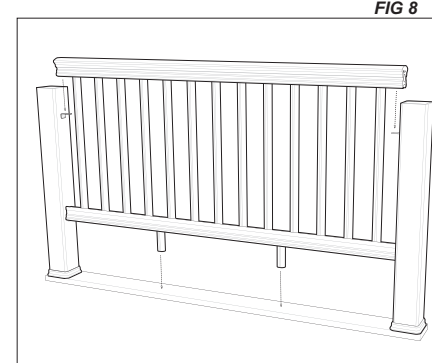

FIG 8

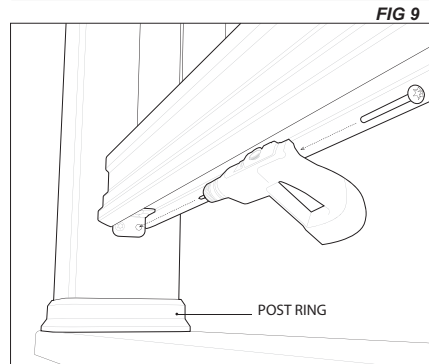

FIG 9

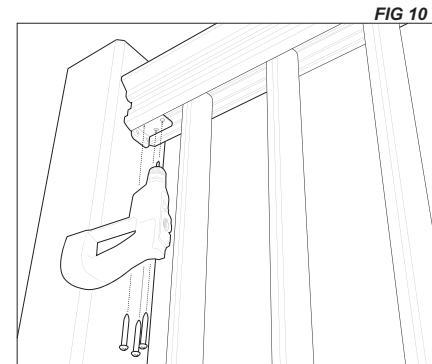

FIG 10

• INSTALLATION

Designer Stair Railing Kit Installation Instructions

1. Install and prepare all mounting surfaces and posts to which your new Designer Railing will be installed. Do not notch posts. For best appearance, cover your 4" x 4" wooden posts with EverGrain post sleeves. **NOTE: Due to various lumber sizes, planing of the wooden posts may be required. The Designer Stair Rail kit provides you with 74" rails. Confirm that your post spacing does not exceed the rail length.**
2. Before installing the EverGrain post sleeve, use a level to ensure that all wood posts are vertically plumb.
3. Measure and cut each post sleeve to the correct height for your rail system. **(Figure 1)**
4. Place the post ring onto the bottom of the post sleeve, and then slide the post sleeve onto the wooden post. The post sleeve must rest flush on the deck surface. **NOTE: Do not force the post sleeve over the post. Due to various lumber sizes, planing of the wooden posts may be required.**
5. Measure and mark both your determined stair rail height and your top stair bracket placement. Pre-drill through the bottom two stair bracket screw holes into the post sleeve. Connect the top two EverGrain stair brackets to the posts with the 2 provided #10 x 2 1/2" screws. **(Figure 2)**
6. Lay the bottom universal rail beside the post sleeves, making sure the single leg is facing the outer perimeter as shown in Figure 3. The rails should extend past the post sleeves on each side, making sure your rail opening does not exceed the stair rail length. Mark both ends of the rail where they cross the post sleeve. Transfer your mark to the top universal rail and hand rail and cut to length and angle. **(Figure 3)**
7. Determine the number of balusters needed for your stair rail section. **NOTE: The balusters should be positioned so that the space between them will not exceed 4".** Measure and mark the baluster screw holes on the bottom universal rail so that the spacing is symmetrical on the rail. **(Figure 4)**
8. Begin to pre-drill the baluster screw holes at the same angle as the rail angle. **NOTE: Use a scrap piece of material as a jig to ensure the pre-drilled hole matches the rail angle.** **(Figure 5)**
9. Align the now pre-drilled bottom rail to the un-drilled top universal rail. Transfer the screw hole marks and pre-drill at the same angle.
10. Remove the number of balusters needed for your stair rail section from your baluster kit. Determine the required baluster length to retain the railing height at the top of the stair run. Mark and cut to angle each end of the balusters, making sure all balusters are equal in length. **(Figure 6)**
11. Position all stair railing components out on a flat work surface, aligning the pre-drilled holes with the correct angles on the universal rails to the pre-cut balusters. **(Figure 7)**
12. Locate the two remaining stair rail brackets in the stair rail kit. Pre-drill through the top of the bracket into the ends of the bottom universal rails and attach with the 3 provided #10 x 1" screws. **(Figure 8)**
13. Locate the crush block in the stair rail kit. It may be necessary to cut the crush block to size. The bottom universal rail must be supported at a maximum of 25" on center. Pre-drill and attach the crush blocks by driving a provided #8 x 3" screw, or a #8 x 3" color coordinating screw (not provided) down through the top of the bottom universal rail. **NOTE: Depending on the stair rail length, it may be necessary to place a crush block on the underneath side of the bottom universal rail. Consult with you local building official for mandatory clearance.**
14. Remove the baluster hardware pack from the baluster kit and begin attaching balusters to the top universal rail using the provided #8 x 3" screws. Repeat for the bottom universal rail. **NOTE: Do not overdrive screws into the balusters.** **(Figure 9)**
15. Slide the handrail over the top universal rail. **(Figure 10)**
16. Lower assembled stair railing section onto the top rail brackets located between the post sleeves. **(Figure 11)**
17. Center the bottom of the stair rail section on the post sleeve. Pre-drill through the bottom stair rail brackets into the post sleeve with the 2 provided #10 x 2 1/2" stair rail bracket screws. **NOTE: A bit extension may be necessary to drive screws.** **(Figure 12)**
18. Pre-drill through the top portion of the stair rail brackets into the underside of the universal rail and attach with the 3 provided #10 x 1" bracket screws. **NOTE: A bit extension may be necessary to drive screws.** **(Figure 13)**
19. Attach the post cap using adhesive.

• CUTTING & DRILLING

When working with EverGrain railing, saw blades and router bits with carbide tips are recommended. For best results, use blades with two teeth per inch. To avoid clogging when drilling holes, frequently remove shavings by raising the drill bit out of the hole.

• HANDLING

EverGrain railing is heavier and more flexible than traditional wood products. Use care and do not attempt to lift or carry more railing than you can safely handle at one time. Proper clothing and safety glasses must be worn at all times when working with railing.

Determination of the effectiveness, suitability, and safety of any application or use of EverGrain railing is solely the responsibility of the Owner and/or Contractor. Building code regulations vary, and the Owner and/or Contractor must consult local building and safety codes for specific requirements prior to the application of EverGrain railing.

• CLEANING

Semi-annual cleaning of your railing is required. Mild stains may be removed with commonly available deck washes containing sodium hypochlorite.

FOR MORE DETAILED CLEANING INFORMATION

Please visit the care and cleaning section on our website at www.evergrain.com.

After cleaning, flush the surface of railing using a garden hose or a power washer hose with a fan-tip nozzle at a pressure not exceeding 1,000 psi to remove any excess cleaning agents.

IMPORTANT NOTE: Sanding the surface to remove stains is not recommended.

• LIMITED WARRANTY

TAMKO Building Products, Inc. provides a 25-year limited warranty for EverGrain products installed in accordance with these written instructions. For a copy of the limited warranty see your EverGrain Dealer or visit www.evergrain.com. **Returns of or claims for product due to any condition that was clearly apparent prior to application/fastening of product, will not be considered after product has been applied/fastened to deck structure, joist, etc.**

• BUILDING CODE APPROVED

ICC Approved (ESR-1625) Refer to code reports on www.evergrain.com for product details.

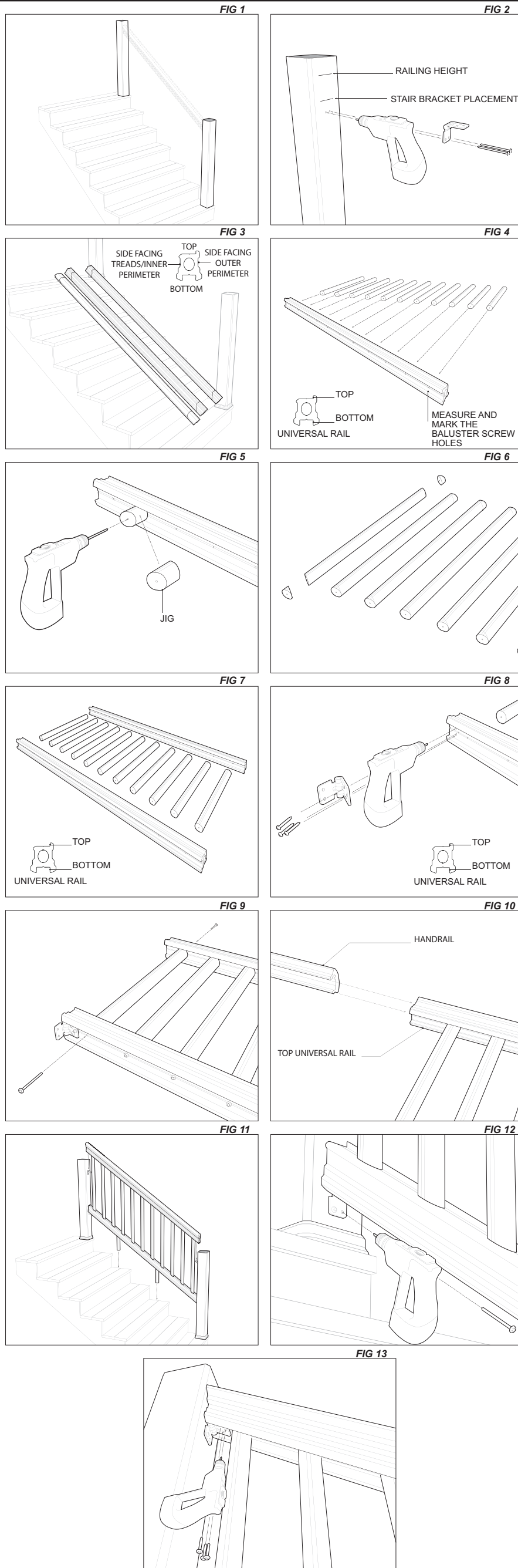

TAMKO Building Products, Inc.

P.O. Box 1404
Joplin, Missouri 64802
• Technical Services: 1-800-253-1401
• Warranty Services: 1-800-441-7190
• Customer Service: 1-800-253-1401

www.evergrain.com

These application instructions were current at the time of printing. To obtain a copy of the most current version of the application instructions, visit us online at www.evergrain.com, or call us at 800-641-4691.