

MOISTURE GUARD PLUS®

Ice & Rain Protective Underlayment

APPLICATION INSTRUCTIONS

THESE ARE THE APPLICATION INSTRUCTIONS FOR MOISTURE GUARD PLUS UNDERLAYMENT. TAMKO BUILDING PRODUCTS SHALL NOT BE RESPONSIBLE FOR LEAKS OR OTHER ROOFING PROBLEMS RESULTING FROM FAILURE TO FOLLOW THESE INSTRUCTIONS. For questions about MOISTURE GUARD PLUS or its application contact TAMKO's Technical Services Department at 800-641-4691.

SURFACE PREPARATION

To begin, remove any dust, dirt, loose nails or other protrusions from the deck of new roofs. Remove all shingles, roofing felt, nails, or other existing roofing materials and debris from the deck of existing roofs. Sweep thoroughly to remove any dust and dirt. For best application, apply MOISTURE GUARD PLUS only in fair weather and when air, substrate, and membrane temperatures are above 35° F.

FOR ROOF DECKS

Apply MOISTURE GUARD PLUS from low to high in shingle fashion as shown below, so that laps will shed water. Overlap edge seams 3-1/2". End seams should be overlapped 6" and staggered. When necessary, the membrane may be unrolled and cut in 10- to 15-foot lengths. Align the membrane on the lower edge of the roof deck. Remove the release film from the membrane then press the membrane into place. Roll lower edges of each course firmly with a wallpaper roller or other hand roller; "Broom in" the installed membrane using an industrial flat broom or squeegee. Bear down on the installed membrane with the broom or squeegee to insure total, even adherence to the substrate. Care should be taken not to damage the surface when brooming. For ice dam protection, MOISTURE GUARD PLUS must be applied to reach a point above the highest expected level of ice dams (minimum application at least 24" beyond the interior wall line.)

FOR VALLEYS AND RIDGES

Where necessary, the membrane may be unrolled and cut into 4- to 6-foot lengths. Peel the release film and center sheet over valley or ridge. Drape and press sheet into place, working from the center of the valley or ridge outward in each direction. For valleys, apply the membrane starting at the lowest point and work upward. Overlap all sheets a minimum of 6 inches. The MOISTURE GUARD PLUS underlayment should be used on "closed valley" applications only. It must be covered by roofing materials. MOISTURE GUARD PLUS underlayment must not be exposed to the elements longer than 90 days before application of the finished roof.

MOISTURE GUARD PLUS UNDERLAYMENT FIELD APPLICATION

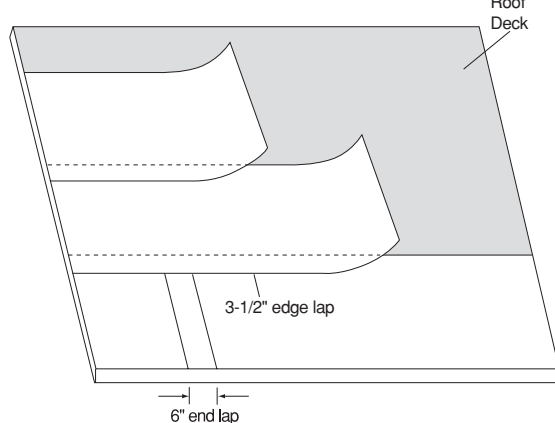

VALLEY FLASHING DETAIL

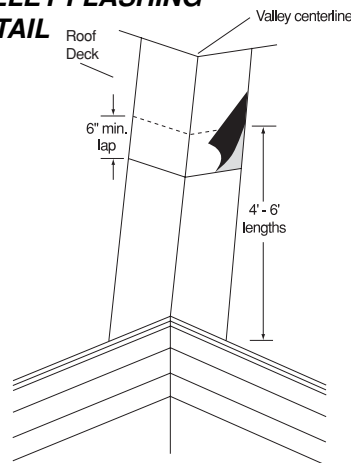

PROVIDE VENTILATION WHEN USING OVER THE ENTIRE ROOF DECK

When using MOISTURE GUARD PLUS underlayment over the entire roof deck the roof must include a system to provide adequate ventilation for all space immediately below the roof deck. Such ventilation system should be designed in accordance with architectural design standards appropriate to the size, nature, and location of the structure and should include both ridge and soffit venting. For further information on providing adequate ventilation, contact your architect, building contractor, building materials supplier, or TAMKO.

IMPORTANT:

Tiles can slide during roof loading and until properly fastened. In order to protect MOISTURE GUARD PLUS underlayment from damage, care must be taken to insure stability of stacked tiles. Fasteners and batten strips must be used when installing tiles over MOISTURE GUARD PLUS underlayment. TAMKO requires the fastening of every tile in addition to mortar, or adhesive or foam regardless of the slope. These are TAMKO's minimum requirements. State and local registrations may contain additional requirements.

CAUTION: The National Institute for Occupational Safety and Health (NIOSH) has concluded that fumes of heated asphalt are a potential occupational carcinogen. Do not burn this product.

tamko.com		
Corporate	220 West 4th Street, Joplin, Missouri 64801	800-641-4691
Central District	220 West 4th Street, Joplin, Missouri 64801	800-641-4691
Northeast District	4500 Tamko Drive, Frederick, Maryland 21703	800-368-2055
Southeast District	2300 35th Street, Tuscaloosa, Alabama 35401	800-228-2656
Southwest District	7910 South Central Expressway, Dallas, Texas 75216	800-443-1834
Western District	5300 East 43rd Avenue, Denver, Colorado 80216	800-530-8868



MOISTURE GUARD PLUS®

Ice & Rain Protective Underlayment

PRODUCT DATA

DESCRIPTION

MOISTURE GUARD PLUS® Underlayment is a self-adhering, fiberglass reinforced, modified bitumen sheet membrane with a mineral surfacing and a removable release film on the adhesive side.

USES

TAMKO MOISTURE GUARD PLUS Underlayment is well suited for use as an underlayment where prevention of water penetration is required prior to installation of the final roof system and as secondary protection against water penetration after installation of the roof system, including protection against wind blown rain and ice damming. Accepted for use on roof decks, along rake and eave edges, valleys and ridges, and around chimneys, dormers, vents, and skylights. Provides an extra layer of protection under most types of roofing, including tile, wood shake, asphalt, slate, or composite shingles. It is not recommended for use under metal roofing.*

ADVANTAGES

- Mineral surfacing provides enhanced skid resistance.
- Strong fiberglass reinforcement for added stability during installation.
- Flexible SBS modified asphalt helps seal around nails to prevent water penetration.
- Split release film for easier installation.
- Meets ASTM D 1970.
- High temperature resistance up to 250° F.
- Can be left exposed for up to 90 days before application of finished roof.
- ICC-ES ESR-1252
- UL Prepared Roofing Accessory
- Florida Building Code Approval # FL 1481

LIMITATIONS

- Membrane should not be applied to damp, frosty, unclean or contaminated surfaces.
- Membrane should not come into contact with products containing coal-tar pitch.
- Best applied at temperatures of 35° F and higher.

PRODUCT DATA**

	1 Square-Slit*** (Slit into two 1/2 square rolls)	1 Square	1.5 Square	2 Square
Roll Size	50 sq. ft.	100 sq. ft.	150 sq. ft.	200 sq. ft.
Roll Dimensions	19-11/16" x 30' 5-3/4"	39-3/8" x 30' 5-3/4"	39-3/8" x 45' 8-1/2"	39-3/8" x 60' 11-1/2"
Thickness	55 mils	55 mils	55 mils	55 mils
Rolls Per Pallet	84 rolls (42 ctns)	40	30	25
Pallet Size	37" x 47"	37" x 47"	37" x 47"	37" x 47"

All values stated as nominal. *Special order only. 1 square equals 100 sq. ft.



TYPICAL PHYSICAL PROPERTIES

Property	Test Method	Typical Value
Tensile Strength, Membrane MD	ASTM D 1970	31 lbf/in.
Tensile Strength, Membrane CD	ASTM D 1970	25 lbf/in.
Elongation MD, min (%)	ASTM D 1970	18 %
Elongation CD, min (%)	ASTM D 1970	18 %
Adhesion to Plywood at 40° F	ASTM D 1970	22 lbf/ft width (min.)
Adhesion to Plywood at 75° F	ASTM D 1970	31 lbf/ft width (min.)
Thermal Stability, max (mm)	ASTM D 1970	0 mm (max)
Low Temp. Flexibility @ -20° F	ASTM D 1970	100% Pass
Tear Resistance MD,	ASTM D 1970	57 lbf
Tear Resistance CD,	ASTM D 1970	46 lbf
Moisture Vapor Permeance, max	ASTM D 1970	0.001 perms (max.)
Sealability around nail	ASTM D 1970	100% Pass
Waterproof Integrity after Low Temp. Flexibility	ASTM D 1970	100% Pass
Waterproof Integrity of Lap Seam	ASTM D 1970	100% Pass
Slip Resistance	ASTM D 1970	100% Pass

* Use TAMKO TW Metal & Tile Underlayment or TW Underlayment for metal roofing applications.