

STRAIGHT RAIL INSTALLATION INSTRUCTIONS

6', 8' or 10' Straight Rail Kit available in 36" or 42" rail heights

IMPORTANT PRODUCT SAFETY AND PRE-INSTALLATION INFORMATION

The following installation instructions are provided to guide you through the installation process of the TAM-RAIL® Straight Rail Kit. TAMKO® Building Products, Inc. shall not be held liable for improper or unsafe installations. Failure to follow these instructions may lead to an unsafe product and will adversely effect coverage under the Limited Warranty. **TAMKO recommends that all designs be reviewed by a licensed architect, engineer or local building official before installation to ensure that they are safe and in compliance with local building code requirements.**

TOOLS REQUIRED FOR INSTALLATION

Tape measure, miter saw or hack saw, drill, #2 square drive bit, level, safety glasses, and hearing protection. For larger construction projects, a miter saw and drill are strongly recommended for quicker installation.

INSTALLATION STEPS

1. Install and prepare posts or other mounting surfaces for TAM-RAIL Railing installation. Ensure mounting surfaces are level and plumb. (Fig. 1) TAMKO recommends using TAM-RAIL Post Mount Systems or wood posts covered with our matching TAM-RAIL Post Sleeve.

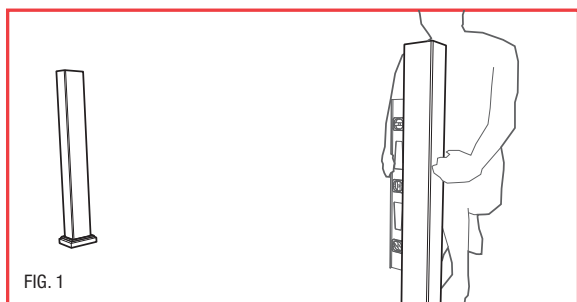

FIG. 1

2. Measure the length between posts and confirm the TAM-RAIL Railing Kit required. (Fig. 2)

IMPORTANT SAFETY INFORMATION: Rail length for 8-foot kits is designed for a maximum allowable rail span of 94" between posts. For more information see CCRR-0118 online at tamko.com or call 1-800-641-4691.

| TAM-RAIL STRAIGHT RAIL KIT RAIL LENGTHS | | | |
|---|---------|---------|------|
| Nominal Rail Length | 6' | 8' | 10' |
| Actual Rail Length, Colonial Balusters | 70-1/4" | 93-7/8" | 120" |
| Actual Rail Length, Square Balusters | 71-3/4" | 95-1/4" | 120" |

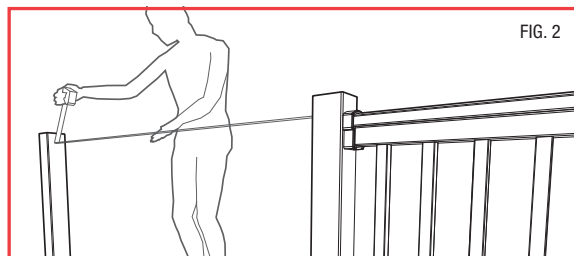
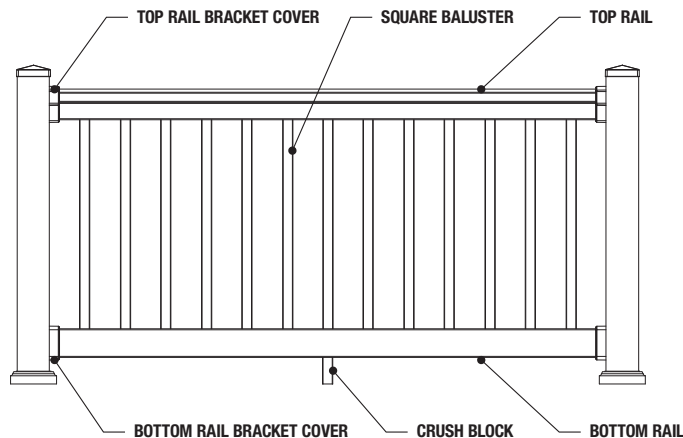

FIG. 2



6' STRAIGHT RAIL KIT COMPONENTS:

- 6' TAM-RAIL Top Rail
- 6' TAM-RAIL Bottom Rail
- Square (13) or Colonial Balusters (14)
- Top Rail Metal Brackets (2)
- Bottom Rail Metal Brackets (2)
- Top Rail Bracket Covers (2)
- Bottom Rail Bracket Covers (2)
- 1" Stainless Screws (13)
- 2" Stainless Screws (13)
- Crush Block (1)
- Bracket Placement Template

8' STRAIGHT RAIL KIT COMPONENTS:

- 8' TAM-RAIL Top Rail
- 8' TAM-RAIL Bottom Rail
- Square (18) or Colonial Balusters (19)
- Top Rail Metal Brackets (2)
- Bottom Rail Metal Brackets (2)
- Top Rail Bracket Covers (2)
- Bottom Rail Bracket Covers (2)
- 1" Stainless Screws (13)
- 2" Stainless Screws (13)
- Crush Block (1)
- Bracket Placement Template

10' STRAIGHT RAIL KIT COMPONENTS:

- 10' TAM-RAIL Top Rail
- 10' TAM-RAIL Bottom Rail
- Square (23) or Colonial Balusters (24)
- Top Rail Metal Brackets (2)
- Bottom Rail Metal Brackets (2)
- Top Rail Bracket Covers (2)
- Bottom Rail Bracket Covers (2)
- 1" Stainless Screws (13)
- 2" Stainless Screws (13)
- Crush Block (2)
- Bracket Placement Template

SUBSTITUTION FOR THESE COMPONENTS IS NOT ALLOWED AS SUBSTITUTING COMPONENTS COULD CAUSE A SAFETY HAZARD.

TABLE OF CONTENTS

| | |
|--|---|
| Straight Rail..... 1 | 45° Fixed Angle Bracket Adapter 8 |
| Stair Rail 3 | 22.5° Fixed Angle Bracket Adapter 10 |
| Wood/Composite Post Mount 5 | Rise/Run Chart 12 |
| Concrete Post Mount 6 | |

CONTINUED

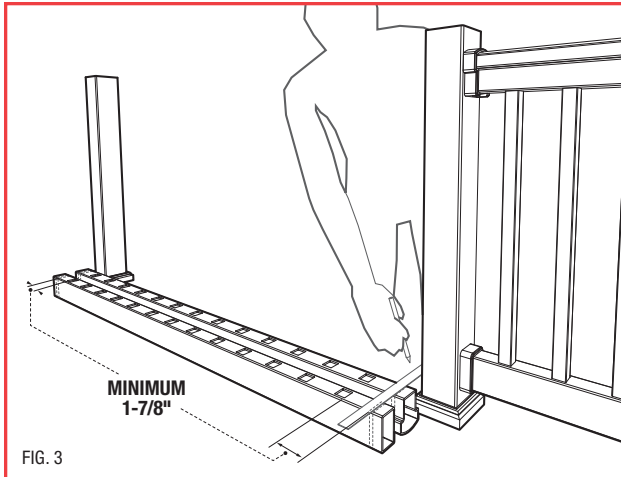

FIG. 3

3. Lay the bottom rail beside the posts with the pre-routed baluster holes facing upward and evenly spaced. Mark the rail with an additional 1/8" removed from each end to compensate for the metal brackets. (Fig. 3)

IMPORTANT: A minimum of 1-7/8" rail length is required from the end of rail to first baluster on both ends of the rail. Check end spacing and shift the position of the rail before cutting if required. **Ensure that the gap between posts and balusters will not exceed 4".**

When positioned and marked properly cut the bottom rail.

IMPORTANT SAFETY INFORMATION: Rail length for 8-foot kits is designed for a maximum allowable rail span of 94" between posts. For more information see CCRR-0118 online at tamko.com or call 1-800-641-4691.

4. Lay the top rail beside the bottom rail with baluster holes aligned. Mark and cut the top rail to match the bottom rail length and end spacing. (Fig. 3)
5. Trim the crush block(s) to appropriate length and insert into the pre-cut hole(s) on the underside of the bottom rail.

NOTE: Typical crush block length is 5-1/4" to allow for a 2" clearance between the deck surface and bottom rail. **Be sure to check with your local building code officials for any bottom rail clearance or rail height requirements.** Improper rail clearance or rail height could cause a safety hazard. The formula for crush block length is: deck surface to bottom rail clearance + 3-1/4".

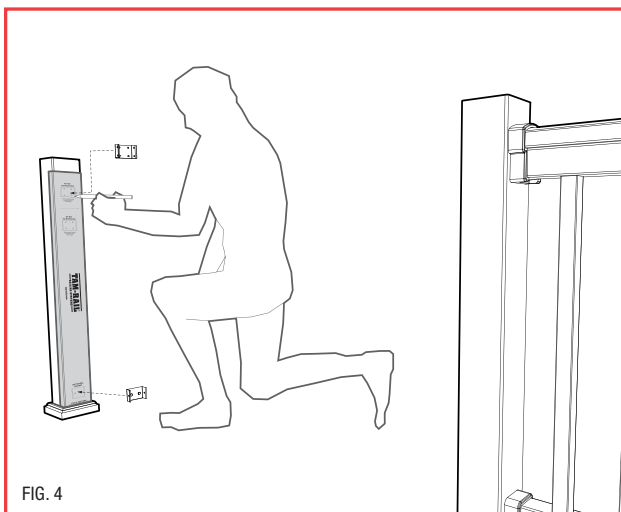

FIG. 4

6. Use the bracket placement template to position the top and bottom metal brackets (marked "T" and "B") and secure brackets in place using the six screws provided, affixing four on top and two on the bottom. (Fig. 4) Use the 2" screws for mounting to a wood post, or the 1" screws included in TAM-RAIL Post Mount kit when mounting to the TAM-RAIL Post Mount System.

NOTE: The template is designed for a 2" clearance from deck surface to bottom rail.

7. Slide bottom bracket covers over the bottom rail and position the rail between the bottom rail metal brackets. (Fig. 5) Level the rail and secure in place on both sides of the metal brackets using two of the 1" screws provided. Snap the bracket covers over the metal brackets.

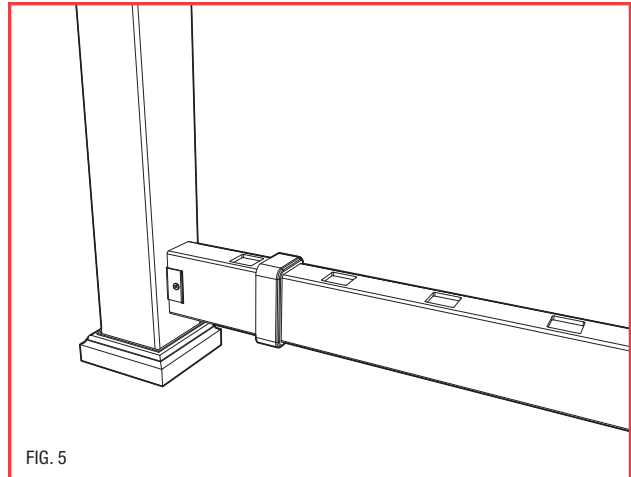

FIG. 5

8. Insert balusters into the pre-routed bottom rail holes. Check with your local code officials for any rail height requirements.

NOTE: Due to the aluminum insert in the 10' rail, the top rail of 10' sections will rest 3/8" higher than the 6' or 8' sections. The bottom of the top rail metal bracket will install flush with the bottom of the top rail. This will not affect the integrity of the railing system.

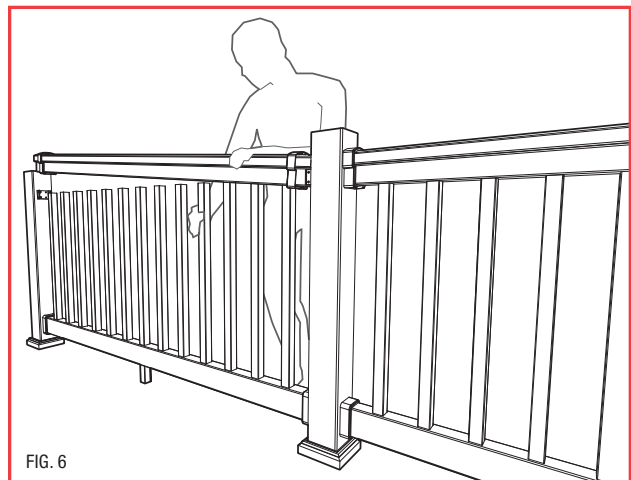

FIG. 6

9. Slide top bracket covers over both ends of the top rail. Align top rail over the balusters and insert balusters one at a time until the top rail is fully installed. (Fig. 6)
10. Secure top rail in place by installing two 1" screws on both sides of the metal brackets. Snap bracket covers over the metal brackets.

STAIR RAIL INSTALLATION INSTRUCTIONS

6' or 8' Stair Rail Kit available in 36" or 42" rail heights

IMPORTANT PRODUCT SAFETY AND PRE-INSTALLATION INFORMATION

The following installation instructions are provided to guide you through the installation process of the TAM-RAIL® Stair Rail Kit. TAMKO® Building Products, Inc. shall not be held liable for improper or unsafe installations. Failure to follow these instructions may lead to an unsafe product and will adversely effect coverage under the Limited Warranty. **TAMKO recommends that all designs be reviewed by a licensed architect, engineer or local building official before installation to ensure that they are safe and in compliance with local building code requirements.**

TOOLS REQUIRED FOR INSTALLATION

Tape measure, miter saw or hack saw, drill, #2 square drive bit, level, safety glasses, and hearing protection. For larger construction projects, a miter saw and drill are strongly recommended for quicker installation.

INSTALLATION STEPS

1. Install and prepare posts for TAM-RAIL Railing installation. Ensure mounting surfaces are level and plumb. (Fig. 1) TAMKO recommends using TAM-RAIL post mount systems or wood posts covered with our matching TAM-RAIL post sleeve.

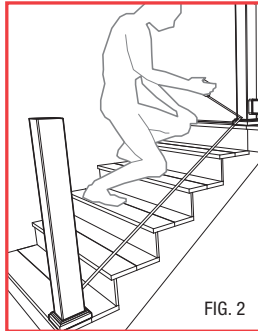
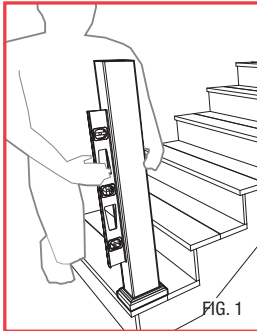

2. Measure the length between posts and confirm the TAM-RAIL Railing Kit required. (Fig. 2)

Refer to the TAM-RAIL Stair Slope Chart on page 12 for the degree of angle required.

| TAM-RAIL STAIR RAIL KIT RAIL LENGTHS | | |
|--------------------------------------|-----|------|
| Nominal Rail Length | 6' | 8' |
| Actual Rail Length | 78" | 102" |

3. Lay the bottom rail beside the posts with baluster holes facing upward. The rail should extend past each of the mounting surfaces. For 8' Rail Kits, verify that the crush block location on the underside of the bottom rail will be positioned securely onto the stair tread.
4. Mark the required rail length with an additional 1/8" removed from each end to compensate for the metal brackets. (Fig. 3)

IMPORTANT: For even end spacing a minimum of 2-3/8" rail length is required from the end of rail to first baluster hole on both ends of the rail. If even end spacing is not required, a minimum of 2-3/8" rail length on the lower end and 2" rail length on the upper end of the rail is allowable. Check end spacing and verify minimum length requirements prior to cutting. **Ensure that the end space gaps between posts and balusters will not exceed 4".**

When positioned and marked cut the bottom rail to the proper angle.

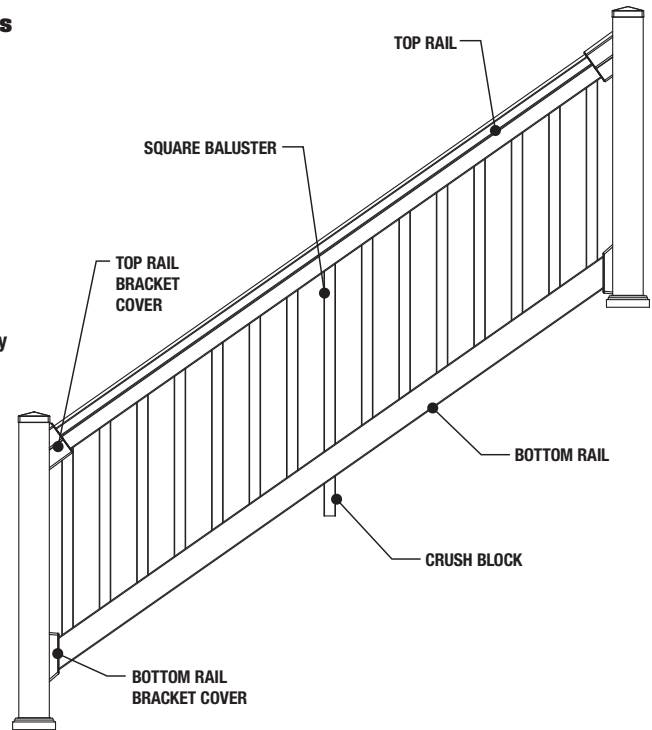

6' STAIR RAIL KIT COMPONENTS:

6' TAM-RAIL Top Rail
6' TAM-RAIL Bottom Rail
Square or Colonial Balusters (11)
Top Rail Metal Brackets (2)
Bottom Rail Metal Brackets (2)
Top Rail Bracket Covers (2)
Bottom Rail Bracket Covers (2)
1" Stainless Screws (13)
2" Stainless Screws (13)

8' STAIR RAIL KIT COMPONENTS:

8' TAM-RAIL Top Rail
8' TAM-RAIL Bottom Rail
Square or Colonial Balusters (15)
Top Rail Metal Brackets (2)
Bottom Rail Metal Brackets (2)
Top Rail Bracket Covers (2)
Bottom Rail Bracket Covers (2)
1" Stainless Screws (13)
2" Stainless Screws (13)
Crush Block (1)

**SUBSTITUTION FOR THESE COMPONENTS IS NOT ALLOWED
AS SUBSTITUTING COMPONENTS COULD CAUSE A SAFETY HAZARD.**

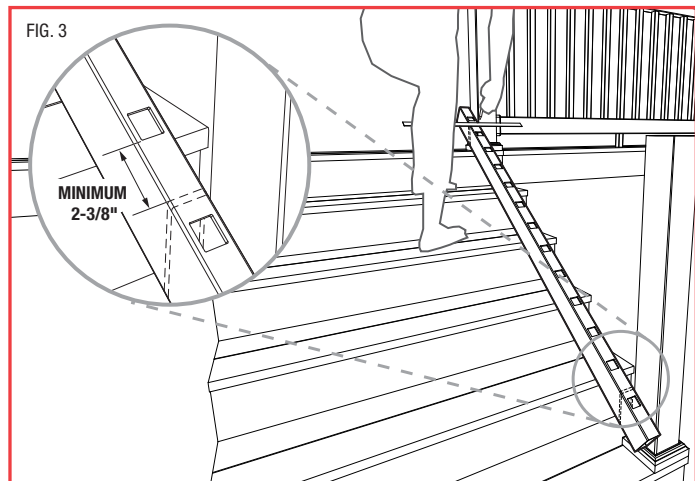

CONTINUED

5. Lay the top rail beside the bottom rail with baluster holes facing and aligned. (Fig. 4) Using a straight edge mark the continuation of the bottom rail angle onto the top rail. Ensure that the end spacing from end of rail to first baluster on each end of the top rail matches the bottom rail end spacing below. Cut the top rail.

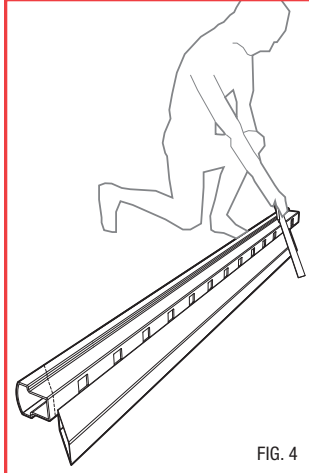

FIG. 4

6. Slide the bracket covers over both ends of the bottom rail and position the bottom rail between posts at the desired height and angle. Mark the location on the posts. (Fig. 5)

SKIP STEP 7 IF YOU ARE INSTALLING A 6' STAIR SECTION

7. Trim the crush block to accommodate the desired bottom rail clearance and insert into the pre-cut hole on the underside of the bottom rail.

Be sure to check with your local building code officials for any bottom rail clearance or rail height requirements. Improper clearance or rail height could cause a safety hazard.

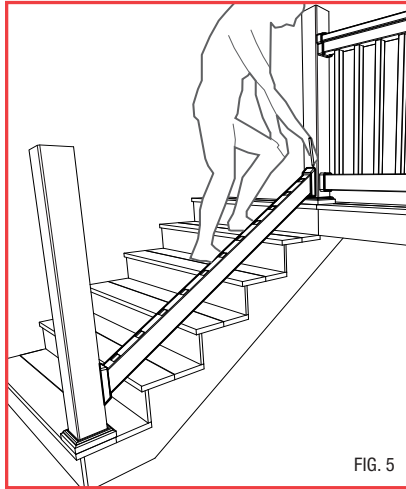

FIG. 5

8. Position the bottom rail metal brackets (marked "B") so that they are centered on both the post and bottom rail and install using two of the screws provided.

Use the 2" screws for mounting to a wood post, or the 1" screws included in TAM-RAIL Post Mount kit when mounting to the TAM-RAIL Post Mount System.

9. Position the rail between the bottom rail metal brackets. (Fig. 6) Level the rail at the desired angle and secure in place on both sides of the metal brackets using two of the 1" screws provided. Snap the bracket covers over the metal brackets.

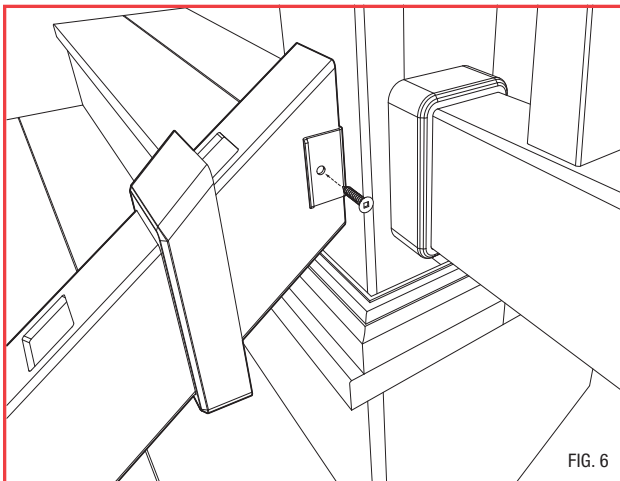

FIG. 6

10. Determine the location of the top rail metal brackets (marked "T"). Insert balusters in the first and last holes of the bottom rail. (Fig. 7) Align top rail over the balusters and install. Ensure the top rail is fully nested and level with the bottom rail. Position the top rail metal brackets on the rail and mark the bracket locations on each post.

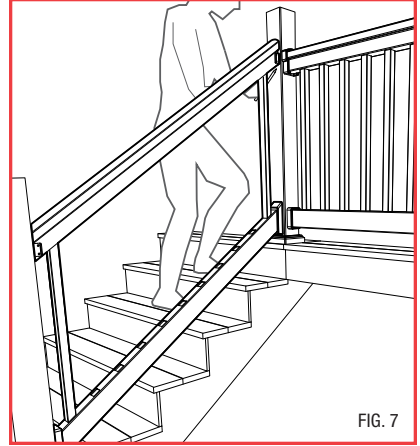

FIG. 7

11. Remove the top rail. Position the top rail metal brackets on the posts and install using four of the screws provided. Use the 2" screws for mounting to a wood post, or the 1" screws included in TAM-RAIL Post Mount kit when mounting to the TAM-RAIL Post Mount System.

12. Insert balusters into the pre-routed bottom rail holes.

13. Slide bracket covers over both ends of the top rail. Align top rail over the balusters and insert balusters one at a time until the top rail is fully installed. (Fig. 8)

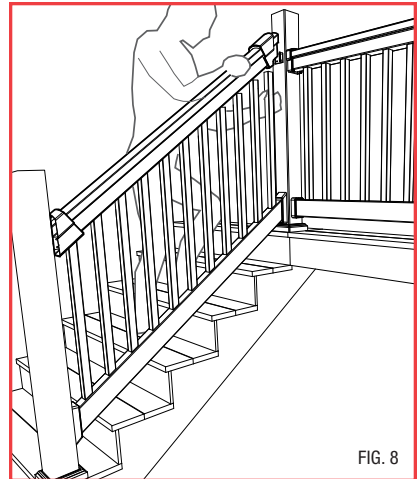

FIG. 8

14. Secure top rail in place by installing two 1" screws on both sides of the metal brackets. (Fig. 9) Snap bracket covers over the metal brackets.

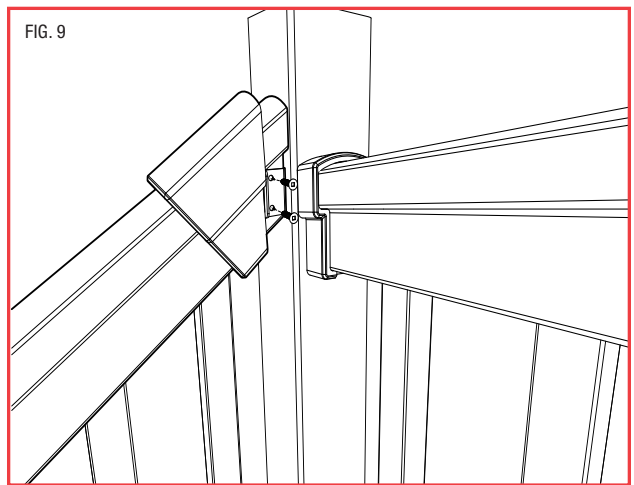

FIG. 9

POST MOUNT INSTRUCTIONS FOR WOOD/COMPOSITE DECK APPLICATION

Post Mount Kit 4" x 4" x 38" for use with all TAM-RAIL® 6', 8' and 10' x 36" Railing Kits
Post Mount Kit 4" x 4" x 44" for use with all TAM-RAIL® 6' and 8' x 42" Railing Kits

IMPORTANT PRODUCT SAFETY AND PRE-INSTALLATION INFORMATION

The following installation instructions are provided to guide you through the installation process of the TAM-RAIL® Wood/Composite Post Mount Kit. TAMKO® Building Products, Inc. shall not be held liable for improper or unsafe installations. Failure to follow these instructions may lead to an unsafe product and will adversely affect coverage under the Limited Warranty.

TAMKO recommends that all designs be reviewed by a licensed architect, engineer or local building official before installation to ensure that they are safe and in compliance with local building code requirements.

TOOLS REQUIRED FOR INSTALLATION:

Tape measure, level, drill, 3/8" drill bit, wrench, safety glasses, and hearing protection.

INSTALLATION STEPS:

1. Reinforce post mount location by installing a minimum 3" of blocking under the mounting location. Cut blocking to the length of the joist span opening and secure with 3" deck screws or nails (not provided) directly under the deck surface.
2. Using the leveling plate as a template, mark the locations of the four mounting holes to be drilled. Drill four holes through the deck and blocking using a 3/8" or 7/16" diameter drill bit.
3. Install the four leveling bolts into the post mount member. Place the leveling plate on the decking surface and align over the four drilled holes. Place the post mount member on top of the leveling plate and align the four holes. Adjust the leveling screws to ensure the post mount member is level.
4. Install the four mounting bolts with washers as shown. On the underside, place the back plate over the exposed mounting bolts. (Use the centered holes for in-line applications and the offset holes for corner applications.) Secure the back plate by using the supplied mounting nuts and washers.

IN-LINE INSTALLATION

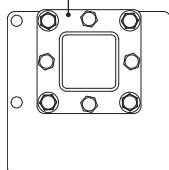

CORNER INSTALLATION

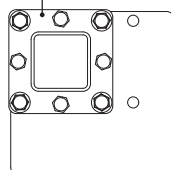

5. Install the two guide blocks onto the post mount member. Position the lower guide block at the bottom of the post and secure in place by installing one of the supplied self-drilling screws through the center of the guide block and into the post until firmly seated. Position the upper guide block so that the top of the guide block is 1" above the top of the post member and secure in place by installing one of the supplied self-drilling screws through the center of the guide block and into the post until firmly seated.
6. Position the post ring over the post sleeve and slide over the post mount system until the post sleeve is flush to the deck surface. Attach the post cap to the post sleeve with PVC glue (not provided).

To install a TAM-RAIL Straight or Stair Rail Kit to the TAM-RAIL Post Mount, use the 1" screws provided in this kit. Refer to the TAM-RAIL Straight or Stair Rail Installation Instructions for details.

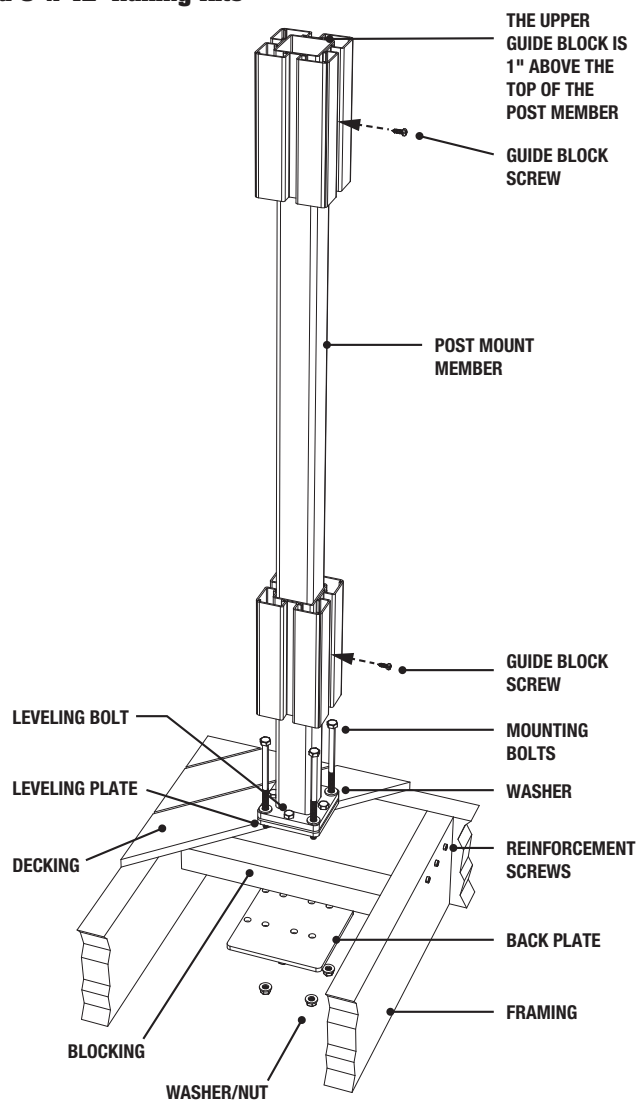

POST MOUNT COMPONENTS:

4" x 4" Post Sleeve (1)
 Pyramid Post Cap (1)
 New England Post Ring (1)
 Post Mount Member (1)
 Guide Blocks (2)
 1" Stainless Steel Screws (13)

WOOD ACCESSORY KIT:

3/4" Self-Drilling Guide Block screws (4)
 Leveling Plate (1)
 5/16" x 1" Leveling Bolts (4)
 5/16" Washers (8)
 Back Plate (1)
 5/16" x 6" Mounting Bolts (4)
 5/16" Mounting Nuts (4)

SUBSTITUTION FOR THESE COMPONENTS IS NOT ALLOWED AS SUBSTITUTING COMPONENTS COULD CAUSE A SAFETY HAZARD.

POST MOUNT INSTRUCTIONS FOR CONCRETE APPLICATION

Post Mount Kit 4" x 4" x 38" for use with all TAM-RAIL® 6' x 36" Railing Kits
Post Mount Kit 4" x 4" x 44" for use with all TAM-RAIL® 6' x 42" Railing Kits

IMPORTANT PRODUCT SAFETY AND PRE-INSTALLATION INFORMATION

The following installation instructions are provided to guide you through the installation process of the TAM-RAIL® Concrete Post Mount Kit. TAMKO® Building Products, Inc. shall not be held liable for improper or unsafe installations. Failure to follow these instructions may lead to an unsafe product and will adversely effect coverage under the Limited Warranty. **TAMKO recommends that all designs be reviewed by a licensed architect, engineer or local building official before installation to ensure that they are safe and in compliance with local building code requirements.**

CONCRETE ANCHORS

TAMKO requires the use of the Hilti HIT-RE 500-SD adhesive anchoring system in the installation of this post mount. The anchoring system must be installed in accordance with Hilti HIT-RE 500-SD Instructions and ESR-2322. Concrete anchors must be installed in dry, normal weight concrete with a specified compressive strength of 2,500 psi to 8,500 psi. In addition, it is the installer's responsibility to ensure that the application and conditions for use of this post mount are in accordance with the Requirements and Limitations provided in Appendix A of these instructions, and TAM-RAIL CCRR-0118. Failure to correctly anchor the post mount in accordance with the above requirements could result in a safety hazard.

For more information regarding HIT-RE 500-SD adhesive anchoring please contact Hilti at 1-800-879-8000 or visit www.Hilti.com.

REQUIREMENTS FOR USE WITH TAM-RAIL 6' RAILING KITS

| Post Mount System | Minimum Concrete Thickness | Minimum Threaded Rod Embedment |
|-------------------|----------------------------|--------------------------------|
| 38" | 4-3/4" | 3-1/2" |
| 44" | 5-1/4" | 4" |

For TAM-RAIL code compliance information, please see Architectural Testing, Inc. CCRR-0118 at tamrail.com

TOOLS REQUIRED FOR INSTALLATION

Tape measure, round steel brush, compressed air, torque wrench, drill, safety glasses, hearing protection, and Hilti MD 2000 or compatible Hilti dispenser.

INSTALLATION STEPS

- Assemble the concrete surface plate to the bottom of the post mount member as shown using four of the supplied 2" coated hex bolts, 3/8" coated lock washers, and coated 3/8" hex nuts (Fig. 1). Tighten nuts to 33 ft-lb using a torque wrench. **Ensure that the hex bolt heads are firmly seated inside the surface plate channels.**
- Determine the post mount location. Using the 5-1/2" x 5-1/2" concrete surface plate as a guide, **ensure that the distance from the edge of the concrete to the edge of the surface plate is at least 4-1/4"**. (Fig. 2)
- Mark the location of the four concrete surface plate corner holes for drilling. (Fig. 2)

IMPORTANT: Before continuing with installation the installer must review and ensure compliance with all Hilti HIT-RE 500-SD instructions and guidelines.

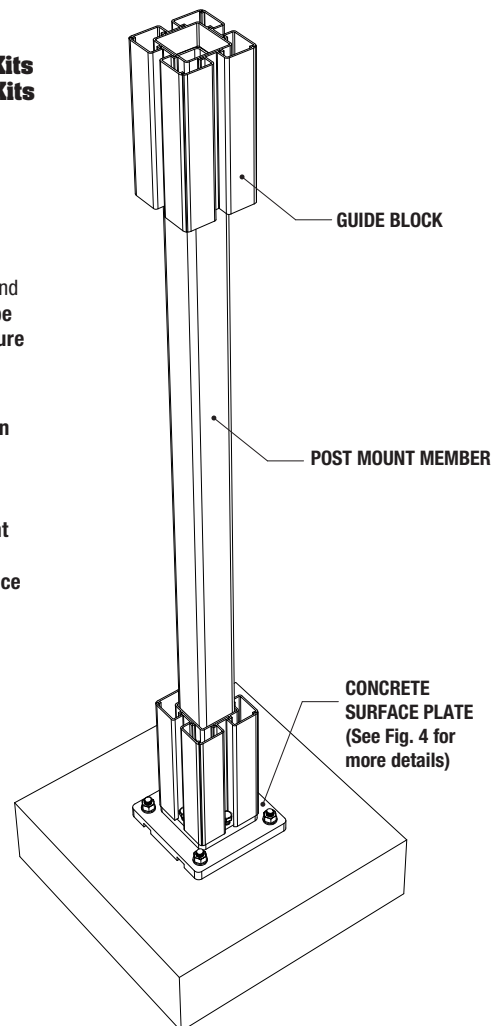
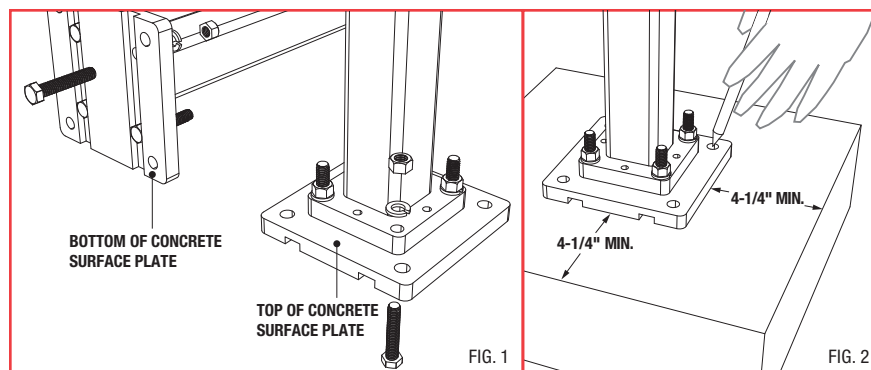

POST MOUNT COMPONENTS:

- 4" x 4" Post Sleeve (1)
- Pyramid Post Cap (1)
- New England Post Ring (1)
- Post Mount Member (1)
- Guide Blocks (2)
- 1" Stainless Steel Screws (13)

CONCRETE ACCESSORY KIT:

- 5-1/2" x 5-1/2" Concrete Surface Plate (1)
- 3/8" x 2" Coated Hex Bolts (4)
- 3/8" Coated Lock Washers (4)
- 3/8" Coated Hex Nuts (4)
- 5/16" x 1" Leveling Bolts (4)
- 3/4" Self-drilling Guide Block screws (4)

CONCRETE ANCHORING SYSTEM

- 3/8" x 5-1/8" Stainless Steel Threaded Rods (4)
- 3/8" Stainless Steel Washers (4)
- 3/8" Stainless Steel Nuts (4)
- Hilti HIT-RE 500-SD Adhesive, 11.1 oz. (1)
- (Hilti Dispenser Not Included)

SUBSTITUTION FOR THESE COMPONENTS IS NOT ALLOWED AS SUBSTITUTING COMPONENTS COULD CAUSE A SAFETY HAZARD.

CONTINUED

- Drill four boreholes into the concrete to the required embedment depth using a hammer drill and 7/16" masonry drill bit. When drilling, check periodically to ensure boreholes remain plumb and aligned with all four of the concrete surface plate corner holes.

REQUIRED EMBEDMENT DEPTH FOR THREADED RODS:

TAM-RAIL 38" Post Mount Kits: 3-1/2"

TAM-RAIL 44" Post Mount Kits: 4"

- Properly clean all boreholes using a 7/16" round steel brush and compressed air (see Hilti HIT-RE 500-SD Instructions, Steps 2-4). **Boreholes must be free of dust, debris, ice, oil, grease and other contaminants.**
- Prepare the HIT-RE 500-SD adhesive for use with a compatible Hilti dispenser and discard initial adhesive (see Hilti HIT-RE 500-SD Instructions, Steps 5-8).
- Inject adhesive into the boreholes without forming air voids, starting from the bottom of each borehole and slowly withdrawing the dispenser. Fill holes approximately 2/3 full or as required to ensure that the annular gap between the threaded rod and concrete is completely filled (see Hilti HIT-RE 500-SD Instructions, Steps 9-10).
- Insert the supplied threaded rods into the boreholes to the required depth, slowly twisting the rods as they are inserted (see Hilti HIT-RE 500-SD Instructions, Steps 11-13). Remove excess epoxy above the boreholes and ensure that the mounting surface remains clear of debris.

IMPORTANT: Once installed correctly, do not disturb the threaded rods until the appropriate setting time has elapsed. Do not install the post mount or apply load to the concrete anchors until the adhesive is fully cured. Follow the adhesive setting guidelines published in the Hilti HIT-RE 500-SD Instructions.

- After the concrete anchors are fully cured, carefully position the post mount over the threaded rods and install flush onto the concrete surface.
- Install four of the supplied stainless steel washers and nuts over the threaded rods and tighten nuts to 15 ft-lb using a torque wrench.
- Check the post with a level. If the post needs to be adjusted for plumb install four of the supplied 1" leveling bolts. (Fig. 3) Adjust the leveling bolts until post is plumb and all four leveling bolts are in contact with the concrete surface plate.

NOTE: It may be necessary to slightly loosen the coated hex nuts to allow the post mount member to be adjusted. **Do not adjust the stainless steel hex nuts used for concrete anchoring.** When post is level, reapply 33 ft-lb torque on coated hex nuts.

- Install the post ring over the concrete surface plate.
- NOTE:** For 38" Post Mount Systems, a portion of the 5-1/8" threaded rods

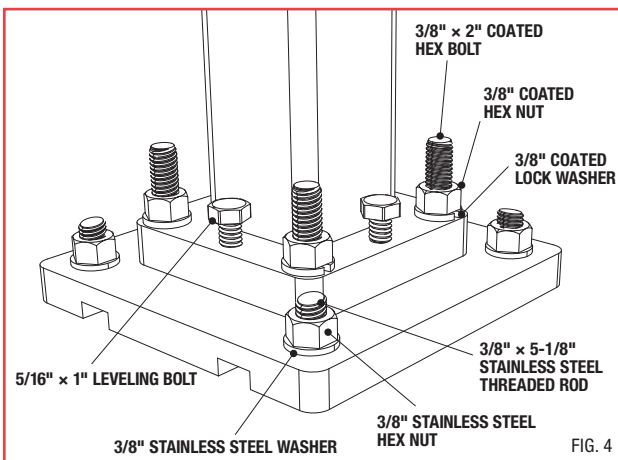

may need to be removed for proper post ring fit. If required, carefully trim the threaded rods ensuring that a minimum of three threads remain above each of the stainless steel nuts. (Fig. 4) Recheck and reapply the required torque on each of the hex nuts.

- Install the two guide blocks onto the post mount member (Fig. 5). Position the lower guide block at the bottom of the post and secure in place by installing one of the supplied self-drilling screws through the center of the guide block and into the post until firmly seated. Position the upper guide block so that the top of the guide block is 1" above the top of the post member and secure in place by installing one of the supplied self-drilling screws through the center of the guide block and into the post until firmly seated.

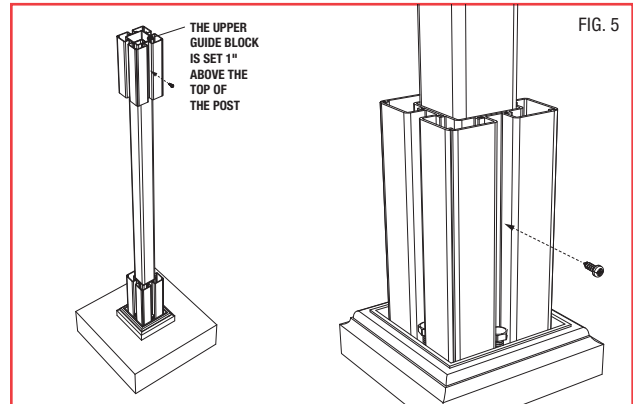

- Trim the TAM-RAIL post sleeve to the desired length and install over the post mount.
- Apply PVC glue (not provided) to the post cap and install over the top of the post sleeve.

To install a TAM-RAIL Straight or Stair Rail Kit to the TAM-RAIL Post Mount, use the 1" screws provided in this kit. Refer to the TAM-RAIL Straight or Stair Rail Installation Instructions for details.

For TAM-RAIL code compliance information, please see Architectural Testing, Inc. CCRR-0118 at tamrail.com

APPENDIX A: TAM-RAIL POST MOUNT SYSTEM INSTALLATION REQUIREMENTS AND LIMITATIONS

- Installation of this post mount system requires the use of Hilti HIT-RE 500-SD Adhesive Anchoring System as described in ICC-ES ESR-2322
- Installation should only be in cracked or uncracked normal weight concrete with a specified compressive strength of 2,500 to 8,500 psi
- Use only the fasteners included with TAM-RAIL Post Mount Kits during this installation
- Installation condition must be dry
- Boreholes must be drilled using a hammer drill with ANSI B212-1994 approved 7/16" carbide bit, and cleaned as described in ESR-2322
- Special Inspection and Jobsite Quality Assurance must be provided in accordance with Sections 4.4 and 4.5 of ESR-2322
- In service concrete Temperature must be per Range A of Table 9 in ESR-2322. Max short term temperature = 110 deg F, Max long term temperature = 80 deg F
- Applied torques to concrete anchors shall not exceed limits established by ESR-2322
- Installation must be in structures assigned to Seismic Design Categories A and B
- Installations are not subject to fatigue or shock loading.
- For installations not consistent with the requirements and limitations noted above and in CCRR-0118, calculations and details demonstrating compliance must be prepared by a licensed Professional Engineer and submitted to the building official having jurisdiction in that area. Otherwise, this installation could be improper and create a safety hazard.

45° FIXED ANGLE ADAPTER INSTALLATION INSTRUCTIONS

Accommodates 45° horizontal angle applications for attaching TAM-RAIL® Straight Rail Kits to a TAM-RAIL Post Mount System, or wood post covered by a TAM-RAIL Post Sleeve

IMPORTANT PRODUCT SAFETY AND PRE-INSTALLATION INFORMATION

The following installation instructions are provided to guide you through the installation process of the TAM-RAIL® 45° Fixed Angle Adapter Kit. TAMKO® Building Products, Inc. shall not be held liable for improper or unsafe installations. Failure to follow these instructions may lead to an unsafe product and will adversely effect coverage under the Limited Warranty. **TAMKO recommends that all designs be reviewed by a licensed architect, engineer or local building official before installation to ensure that they are safe and in compliance with local building code requirements.**

TOOLS REQUIRED FOR INSTALLATION

Tape measure, pencil, drill, safety glasses, and hearing protection.

INSTALLATION STEPS

1. Install and prepare all mounting surfaces and posts to which the TAM-RAIL Railing will be installed. Ensure the mounting surface is level and plumb. TAMKO recommends using TAM-RAIL post mount systems or wood posts covered with our matching TAM-RAIL post sleeve.
2. Measure and mark post 6" above the deck surface.
3. Position the bottom rail angle adapter on the post so that the top of the adapter is 6" above the deck surface. Place the bottom rail metal bracket (marked "B") included in TAM-RAIL railing kits onto the face of the bottom rail angle adapter.
Note: These installation instructions provide a 2" clearance between your deck surface and bottom rail. **Be sure to check with your local building code officials for any bottom rail clearance or rail height requirements. Improper rail height and clearance could create a safety hazard.**
4. Install the bottom rail metal bracket and angle adapter to the post using two of the 2" screws provided in the TAM-RAIL railing kits. Ensure angle adapters are installed evenly and flush to post corners.
5. For 36" height rail systems, measure 36-1/2" above the deck surface and mark post. For 42" height rail systems, measure 42-1/2" above the deck surface and mark post.
6. Position the top rail adapter on the post so that the top of the adapter is aligned with the mark. Place the top rail metal bracket (marked "T") included in TAM-RAIL railing kits onto the face of the top rail angle adapter.
7. Install the top rail metal bracket and angle adapter to the post using four 2" screws provided in the TAM-RAIL railing kits.

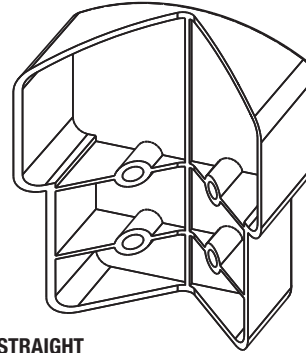

45° FIXED ANGLE ADAPTER KIT COMPONENTS:

Top Rail Angle Adapter (1)

Bottom Rail Angle Adapter (1)

SUBSTITUTION FOR THESE COMPONENTS IS NOT ALLOWED AS SUBSTITUTING COMPONENTS COULD CAUSE A SAFETY HAZARD.

STRAIGHT
TOP RAIL ADAPTER

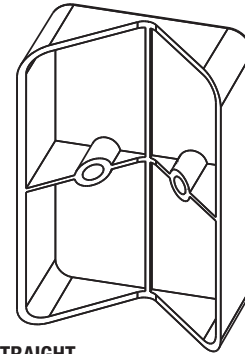

STRAIGHT
BOTTOM RAIL ADAPTER

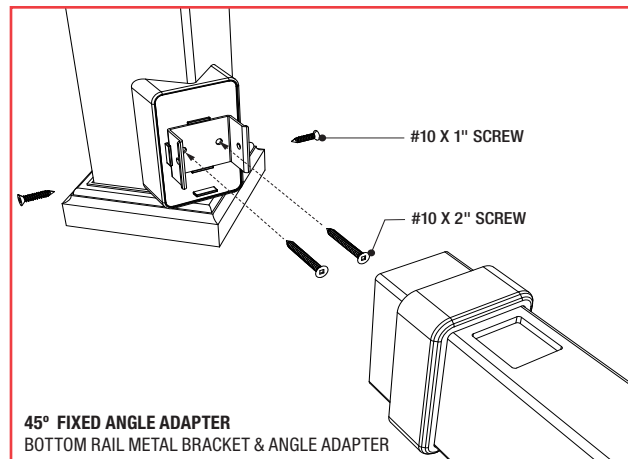
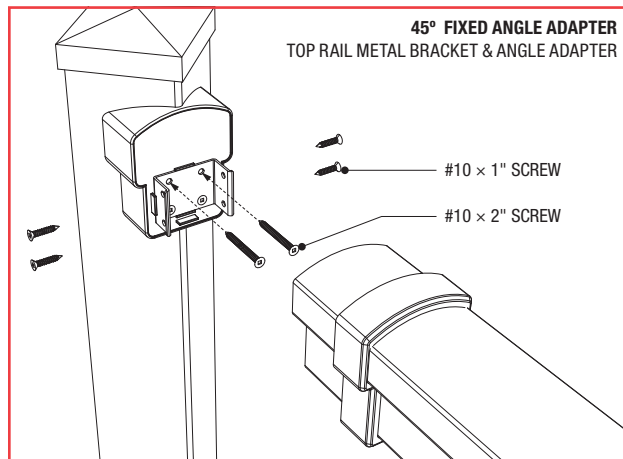

CONTINUED

INSTRUCTIONS FOR INSTALLING STRAIGHT RAIL KITS BETWEEN POSTS WITH PRE-INSTALLED ANGLE ADAPTERS:

1. Measure opening between the bottom rail metal brackets. Mark the length on the bottom rail, ensuring that the balusters will be evenly spaced between posts.

IMPORTANT: A minimum of 1-7/8" rail length is required from the end of rail to first baluster on both ends of the rail. Check end spacing and shift the position of the rail before cutting if required. **Ensure that the gap between posts and balusters will not exceed 4".**

2. When marked properly cut the bottom rail.

Refer back to the TAM-RAIL Straight Rail Installation Instructions for installing TAM-RAIL Straight Rail Kits.

INSTRUCTIONS FOR INSTALLING STRAIGHT RAIL KITS BETWEEN A POST WITH PRE-INSTALLED ANGLE ADAPTERS AND A FLAT POST SURFACE:

1. Use the bracket placement template included in the TAM-RAIL Straight Rail Kits to position the top and bottom metal brackets on the flat post surface.
2. Secure the metal brackets to the flat post surface using six screws, affixing four on top and two on the bottom. Use the 2" screws included in the TAM-RAIL Straight Rail Kits for mounting to a wood post, or the 1" screws included in TAM-RAIL Post Mount Kit when mounting to the TAM-RAIL Post Mount System.
3. Measure the opening between the bottom rail metal brackets. Mark the length on the bottom rail, ensuring that the balusters will be evenly spaced.

IMPORTANT: A minimum of 1-7/8" rail length is required from the end of rail to first baluster on both ends of the rail. Check end spacing and shift the position of the rail before cutting if required. **Ensure that the gap between posts and balusters will not exceed 4".**

4. When marked properly cut the bottom rail.

Refer back to the TAM-RAIL Straight Rail Installation Instructions for installing TAM-RAIL Straight Rail Kits.

STRAIGHT RAIL KIT MOUNTED BETWEEN ANGLE ADAPTER AND A FLAT POST SURFACE

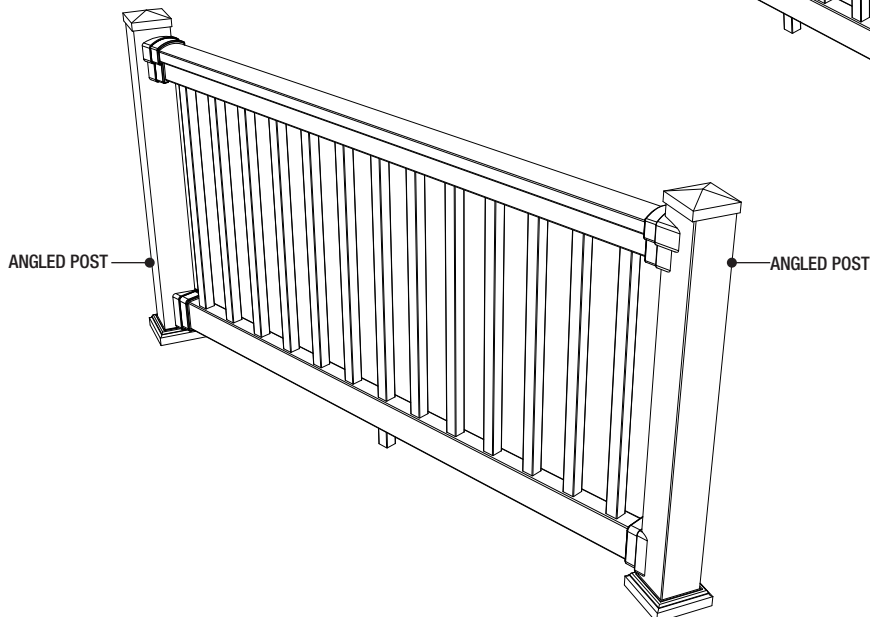
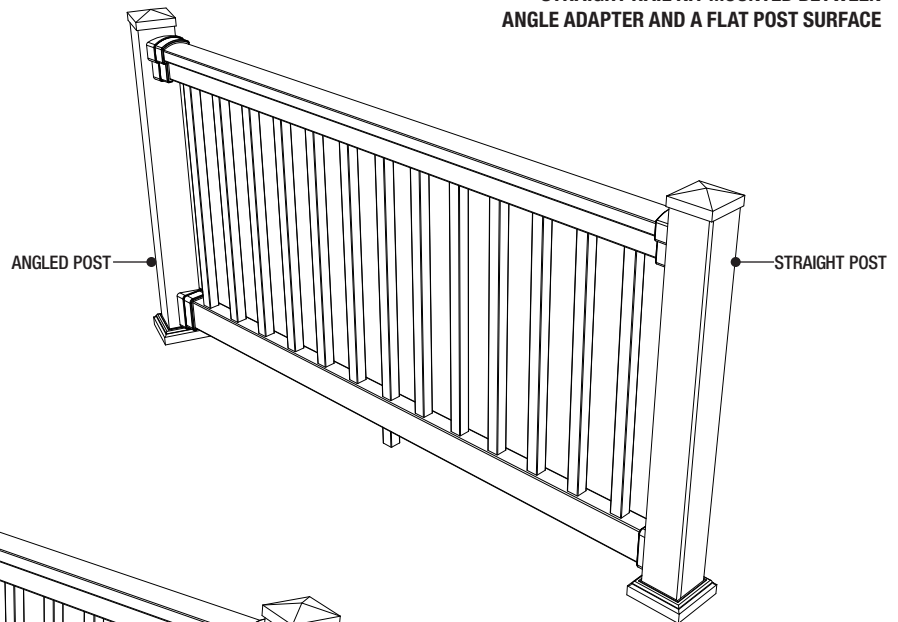

STRAIGHT RAIL KIT MOUNTED BETWEEN ANGLE ADAPTERS

22.5° FIXED ANGLE ADAPTER INSTALLATION INSTRUCTIONS

Accommodates 22.5° horizontal angle applications for attaching TAM-RAIL® Straight Rail Kits to a TAM-RAIL Post Mount System or wood post covered by a TAM-RAIL Post Sleeve

IMPORTANT PRODUCT SAFETY AND PRE-INSTALLATION INFORMATION

The following installation instructions are provided to guide you through the installation process of the TAM-RAIL® 22.5° Fixed Angle Adapter Kit. TAMKO® Building Products, Inc. shall not be held liable for improper or unsafe installations. Failure to follow these instructions may lead to an unsafe product and will adversely effect coverage under the Limited Warranty. **TAMKO recommends that all designs be reviewed by a licensed architect, engineer or local building official before installation to ensure that they are safe and in compliance with local building code requirements.**

TOOLS REQUIRED FOR INSTALLATION

Tape measure, pencil, drill, safety glasses, and hearing protection.

INSTALLATION INSTRUCTIONS FOR WOOD POST APPLICATIONS

1. Install and prepare all mounting surfaces and posts to which the TAM-RAIL Railing will be installed. Ensure the mounting surface is level and plumb.
2. Measure and mark post 6" above the deck surface.

Note: These installation instructions provide a 2" clearance between your deck surface and bottom rail. **Be sure to check with your local building code officials for any bottom rail clearance or rail height requirements. Improper rail heights and clearance can create a safety hazard.**

3. Position the bottom rail angle adapter on the post so that the top of the adapter is 6" above the deck surface. Place the bottom rail metal bracket (marked "B") included in TAM-RAIL railing kits onto the face of the bottom rail angle adapter.
4. Install the bottom rail metal bracket and angle adapter to the post using two of the 2" screws provided in the TAM-RAIL Straight Rail Kits. Ensure angle adapters are installed evenly and flush to post corners.
5. For 36" height rail systems, measure 36-1/2" above the deck surface and mark post. For 42" height rail systems, measure 42-1/2" above the deck surface and mark post.
6. Position the top rail adapter on the post so that the top of the adapter is aligned with the mark. Place the top rail metal bracket (marked "T") included in TAM-RAIL railing kit onto the face of the top rail angle adapter.
7. Install the top rail metal bracket and angle adapter to the post using two of the 2" screws provided in the TAM-RAIL railing kits.

22.5° FIXED ANGLE ADAPTER KIT COMPONENTS:

- Top Rail Angle Adapter (1)
- Bottom Rail Angle Adapter (1)
- #10 × 1-3/4" screws (5)
- #10 × 3" self-drilling screws (3)

SUBSTITUTION FOR THESE COMPONENTS IS NOT ALLOWED AS SUBSTITUTING COMPONENTS COULD CAUSE A SAFETY HAZARD.

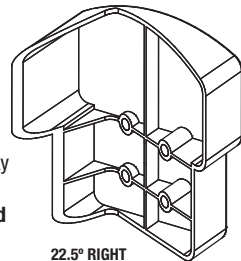

22.5° RIGHT
STRAIGHT TOP RAIL
ADAPTER

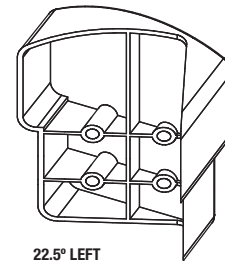

22.5° LEFT
STRAIGHT TOP RAIL
ADAPTER

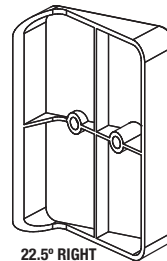

22.5° RIGHT
STRAIGHT BOTTOM
ADAPTER

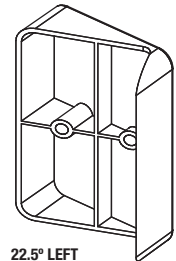

22.5° LEFT
STRAIGHT BOTTOM
ADAPTER

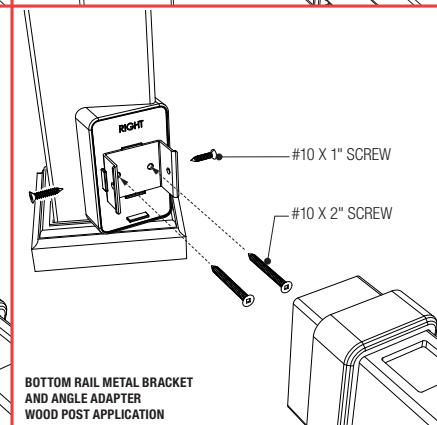
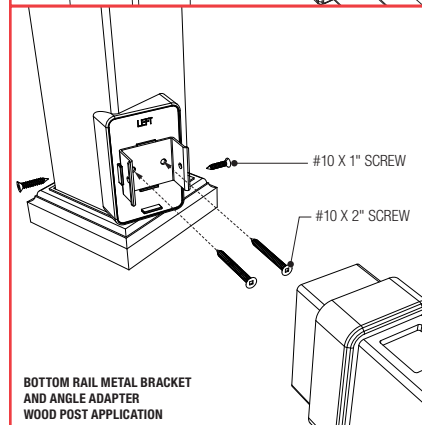
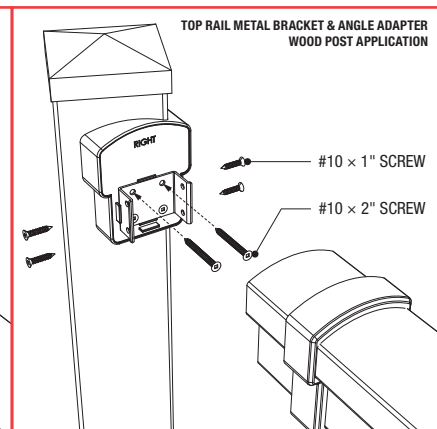
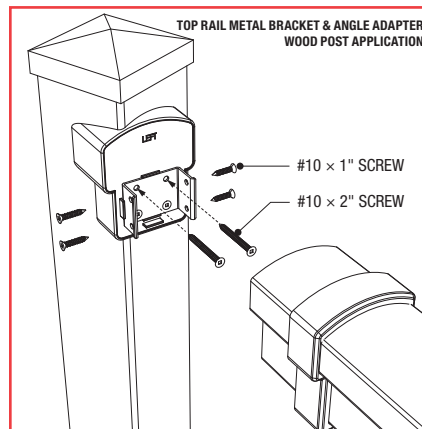

CONTINUED

INSTALLATION INSTRUCTIONS FOR POST MOUNT APPLICATIONS

1. Install and prepare all mounting surfaces and posts to which the TAM-RAIL Railing will be installed. Ensure the mounting surface is level and plumb.
2. Measure and mark post 6" above the deck surface.
3. Position the bottom rail angle adapter on the post so that the top of the adapter is 6" above the deck surface. Place the bottom rail metal bracket (marked "B") included in TAM-RAIL railing kits onto the face of the bottom rail angle adapter.

Note: These installation instructions provide a 2" clearance between your deck surface and bottom rail. **Be sure to check with your local building code officials for any bottom rail clearance or rail height requirements. Improper rail height and clearance can create a safety hazard.**

4. Install the bottom rail metal bracket and angle adapter to the post using two of the supplied 1-3/4" screws. Ensure angle adapters are installed evenly and flush to post corners.
5. For 36" height rail systems, measure 36-1/2" above the deck surface and mark post. For 42" height rail systems, measure 42-1/2" above the top of the deck surface and mark post.
6. Position the top rail angle adapter on the post so that the top of the adapter is aligned with the mark. Place the top rail metal bracket (marked "T") included in TAM-RAIL railing kit onto the face of the top rail angle adapter.
7. Install the top rail metal bracket and angle adapter to the post as illustrated and according to these instructions:
 - a. When installing a "LEFT" top rail angle adapter, install two of the supplied 1-3/4" screws through the left-side holes of the metal bracket and angle adapter. Install two of the supplied 3" self-drilling screws through the right-side holes and into the metal post.
 - b. When installing a "RIGHT" top rail angle adapter, install two of the supplied 1-3/4" screws through the right-side holes of the metal bracket and angle adapter. Install two of the supplied 3" self-drilling screws through the left-side holes and into the metal post.

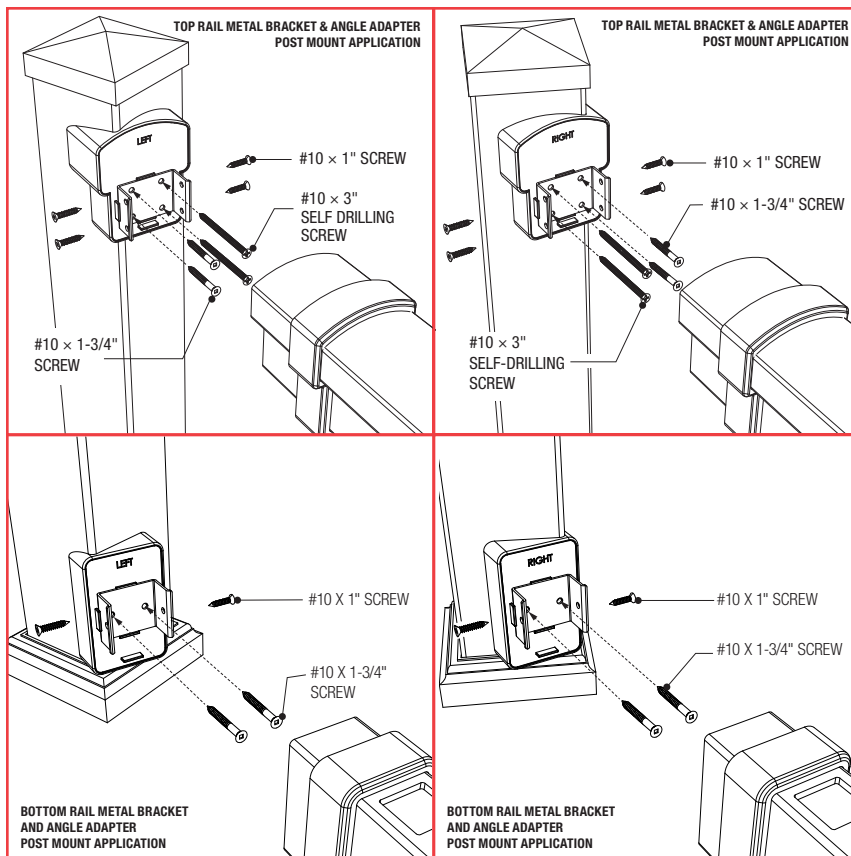

INSTRUCTIONS FOR INSTALLING STRAIGHT RAIL KITS BETWEEN POSTS WITH PRE-INSTALLED ANGLE ADAPTERS:

1. Measure opening between the bottom rail metal brackets. Mark the length on the bottom rail, ensuring that the balusters will be evenly spaced between posts.

IMPORTANT: A minimum of 1-7/8" rail length is required from the end of rail to first baluster on both ends of the rail. Check end spacing and shift the position of the rail before cutting if required. **Ensure that the gap between posts and balusters will not exceed 4".**

2. When marked properly cut the bottom rail.

Refer back to the TAM-RAIL Straight Rail Installation Instructions for installing TAM-RAIL Straight Rail Kits.

INSTRUCTIONS FOR INSTALLING STRAIGHT RAIL KITS BETWEEN A POST WITH PRE-INSTALLED ANGLE ADAPTERS AND A FLAT POST SURFACE:

1. Use the bracket placement template included in the TAM-RAIL Straight Rail Kits to position the top and bottom metal brackets on the flat post surface.
2. Secure the metal brackets to the flat post surface using six screws, affixing four on top and two on the bottom. Use the 2" screws included in the TAM-RAIL Straight Rail Kits for mounting to a wood post, or the 1" screws included in TAM-RAIL Post Mount Kit when mounting to the TAM-RAIL Post Mount System.
3. Measure the opening between the bottom rail metal brackets. Mark the length on the bottom rail, ensuring that the balusters will be evenly spaced. **IMPORTANT:** A minimum of 1-7/8" rail length is required from the end of rail to first baluster on both ends of the rail. Check end spacing and shift the position of the rail before cutting if required. **Ensure that the gap between posts and balusters will not exceed 4".**
4. When marked properly cut the bottom rail.

Refer back to the TAM-RAIL Straight Rail Installation Instructions for installing TAM-RAIL Straight Rail Kits.

CONTINUED

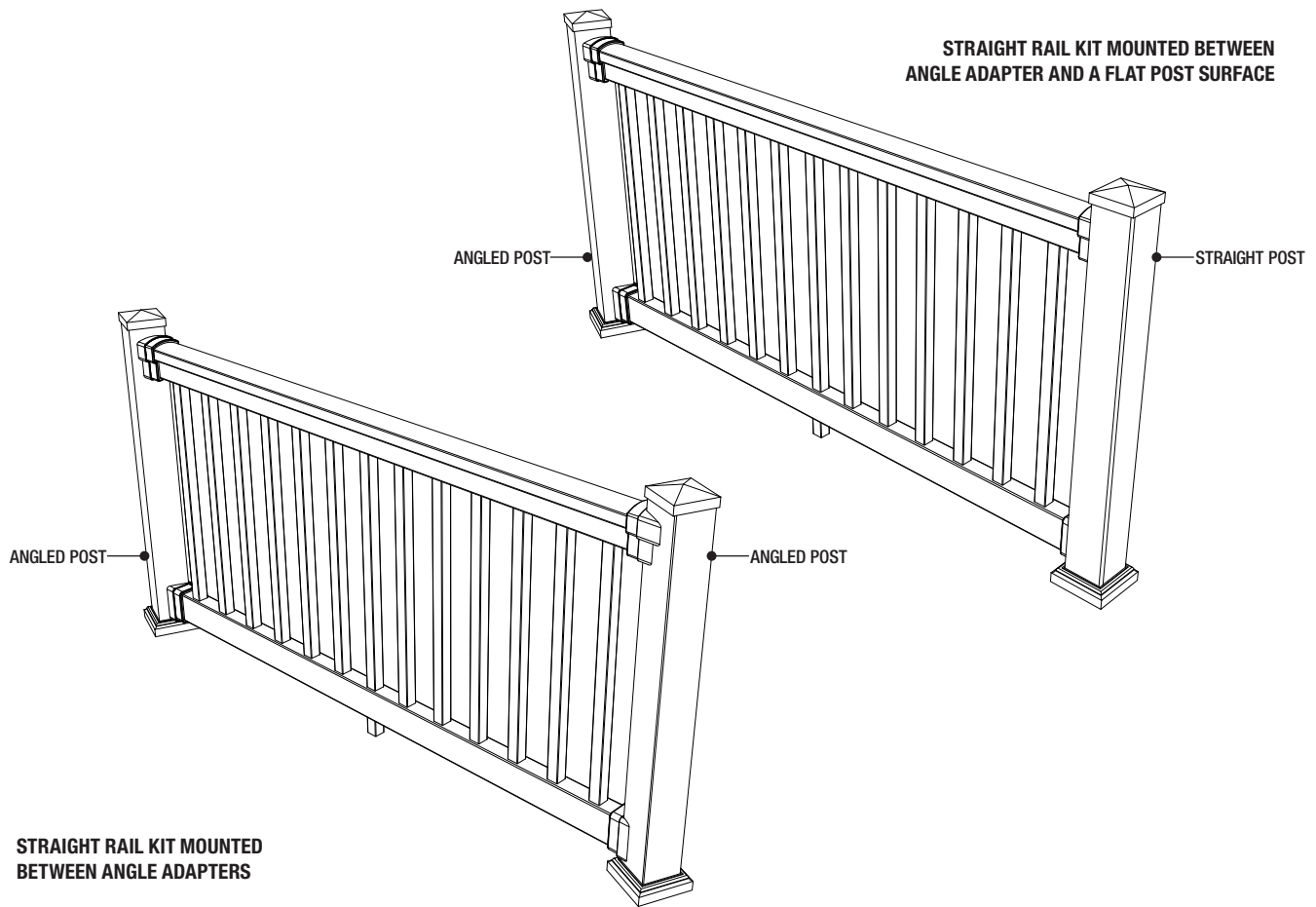

TAM-RAIL® Stair Slope Chart

| RUN (inches) | | 6.5 | 7 | 7.5 | 8 | 8.5 | 9 | 9.5 | 10 | 10.5 | 11 | 11.5 | 12 | 12.5 | 13 | 13.5 | 14 | 14.5 | 15 |
|---------------|-----|-----|----|-----|----|-----|----|-----|----|------|----|------|----|------|----|------|----|------|----|
| RISE (inches) | 3.5 | 28 | 27 | 25 | 24 | 22 | 21 | 20 | 19 | 18 | 18 | 17 | 16 | 16 | 15 | 15 | 14 | 14 | 13 |
| | 4 | 32 | 30 | 28 | 27 | 25 | 24 | 23 | 22 | 21 | 20 | 19 | 18 | 18 | 17 | 17 | 16 | 15 | 15 |
| | 4.5 | 35 | 33 | 31 | 29 | 28 | 27 | 25 | 24 | 23 | 22 | 21 | 21 | 20 | 19 | 18 | 18 | 17 | 17 |
| | 5 | 38 | 36 | 34 | 32 | 30 | 29 | 28 | 27 | 25 | 24 | 23 | 23 | 22 | 21 | 20 | 20 | 19 | 18 |
| | 5.5 | 40 | 38 | 36 | 35 | 33 | 31 | 30 | 29 | 28 | 27 | 26 | 25 | 24 | 23 | 22 | 21 | 21 | 20 |
| | 6 | 43 | 41 | 39 | 37 | 35 | 34 | 32 | 31 | 30 | 29 | 28 | 27 | 26 | 25 | 24 | 23 | 22 | 22 |
| | 6.5 | 45 | 43 | 41 | 39 | 37 | 36 | 34 | 33 | 32 | 31 | 29 | 28 | 27 | 27 | 26 | 25 | 24 | 23 |
| | 7 | 47 | 45 | 43 | 41 | 39 | 38 | 36 | 35 | 34 | 32 | 31 | 30 | 29 | 28 | 27 | 27 | 26 | 25 |
| | 7.5 | 49 | 47 | 45 | 43 | 41 | 40 | 38 | 37 | 36 | 34 | 33 | 32 | 31 | 30 | 29 | 28 | 27 | 27 |
| | 8 | 51 | 49 | 47 | 45 | 43 | 42 | 40 | 39 | 37 | 36 | 35 | 34 | 33 | 32 | 31 | 30 | 29 | 28 |
| 8.5 | 53 | 51 | 49 | 47 | 45 | 43 | 42 | 40 | 39 | 38 | 36 | 35 | 34 | 33 | 32 | 31 | 30 | 30 | |
| 9 | 54 | 52 | 50 | 48 | 47 | 45 | 43 | 42 | 41 | 39 | 38 | 37 | 36 | 35 | 34 | 33 | 32 | 31 | |
| 9.5 | 56 | 54 | 52 | 50 | 48 | 47 | 45 | 44 | 42 | 41 | 40 | 38 | 37 | 36 | 35 | 34 | 33 | 32 | |
| 10 | 57 | 55 | 53 | 51 | 50 | 48 | 46 | 45 | 44 | 42 | 41 | 40 | 39 | 38 | 37 | 36 | 35 | 34 | |

- Stair Rail 30-35° Bracket included in kit
- Stair Rail 36-41° Bracket included in kit

© 2011 TAMKO Building Products, Inc. TAMKO and TAM-RAIL are Registered Trademarks of TAMKO Building Products, Inc. It is the responsibility of the installer to meet all building code and safety requirements and to obtain all required building permits. For Tam-Rail code compliance information see CCRR-0118. TAMKO Building Products, Inc. shall not be held liable for improper or unsafe installations. These application instructions were current at the time of printing. To obtain a copy of the most current version of the application instructions or of Tam-Rail CCRR-0118, visit us online at tamrail.com or call us at 1-800-641-4691.

