



Code Compliance Research Report

CCRR-0118

Subject to Renewal: 04/15/2013
Visit www.archtest.com for current status

Issued: 04/15/2011
Revision: 12/13/2011
Page 1 of 14

TAMKO Building Products, Inc.
220 West 4th Street
Joplin, MO 64801

(800)-641-4691
www.tamko.com

1.0 Subject

Guardrail Systems

TAMKO TAM-RAIL[®] Railing System

2.0 Research Scope

2.1. Building codes

- 2006, 2009 International Building Code(IBC)
- 2006, 2009 International Residential Code(IRC)
- 2007 Florida Building Code (FBC)
Building and Residential
(excluding High Velocity Hurricane Zones)

2.2. Properties

- Structural Performance
- Durability
- Surface Burning
- Decay Resistance
- Termite Resistance

3.0 Description

3.1. General – The TAM-RAIL[®] Railing System is a guard or guardrail under the definitions of the referenced codes. They are intended for use at or near the open sides of elevated walking areas of buildings and walkways as required by the referenced codes.

3.2. The TAM-RAIL[®] Railing System is provided as level guards with heights of 36” or 42” above the floor surface and is provided in rail lengths for nominal 6, 8, and 10 foot guard systems. See Table 1.

3.3. The TAM-RAIL[®] Railing System is provided as stair guards up to 100 inches in length as measured along the top rail. See Table 1.

3.4. The TAM-RAIL[®] Railing System includes upper and lower rails, vertical balusters, 4X4 post sleeve, TAM-RAIL[®] post mount system, rail-to-post brackets and hardware, rail-to-post bracket covers, fixed angle adapters, crush block, post trim ring and post cap.

3.4.1. The breadloaf shaped top rail, rectangular bottom rail, 1.5” colonial balusters, 1.5” square balusters and a 4X4 post sleeve, are hollow extrusions manufactured using a tri-layered extrusion process. These extrusions consist of a core layer of PVC (Poly Vinyl Chloride) and wood composite capped by an inner and outer layer of PVC. See Figures 1, 2 and 3 for sectional profiles.

3.4.2. Both the top and bottom rails have pre-routed square holes to receive the ends of the balusters at assembly. The baluster assembly limits the spacing between balusters such that a 4 inch diameter sphere cannot pass through at any location.

3.4.3. A crush block is utilized as a support block after being inserted into routed openings on the bottom of the lower rail.

3.4.4. For level guardrail assemblies greater than 94” and less than or equal to 120” in length, an aluminum stiffener insert is utilized inside the upper rail only. See Figure 1.

3.4.5. Composite and PVC components recognized for use in the TAM-RAIL[®] Railing System are manufactured in white, taupe and grey colors.

3.5. Structural supports may be conventional wood framing or a TAM-RAIL[®] post mount system (See Figures 8 and 9). A TAM-RAIL 4X4 post sleeve is utilized with both conventional 4X4 wood posts and the TAM-RAIL post mount systems.

3.6. The TAM-RAIL[®] post mount system is comprised of a 2” square steel tube welded to a 0.650” thick base plate for anchorage. Two molded PVC spacer/mounting (guide) blocks provide for attachment of rail brackets. See Figure 8.

3.6.1. For attachment of the *TAM-RAIL*[®] post mount system to wood composite decking systems, additional components are provided and includes a steel leveling plate, a steel back plate and hardware. See Figure 8.

3.6.2. For attachment of the *TAM-RAIL*[®] post mount system to concrete, the system is provided with an additional 5 ½" square, 0.551" thick steel surface plate (See Figure 11), 3/8" dia x 5.125" stainless steel anchor rods, Hilti HIT-RE 500-SD Anchor adhesive and associated hardware. See Figures 9 thru 11.

3.7. Stainless steel brackets and associated hardware recognized for use with level and stair constructions are as indicated in Figures 4 and 5.

3.8. Molded PVC fixed angle adapters and associated hardware recognized for use in angled assemblies of 22.5° and 45° are as shown in Figures 6, 7 and Table 2.

4.0 Performance Characteristics

4.1. The *TAM-RAIL*[®] Railing System described in this report has demonstrated the capacity to resist the design loadings specified in Chapter 16 of the IBC, FBC and Section R301 of IRC, when tested in accordance with ICC-ES AC174.

4.2. Structural performance has been demonstrated for a temperature range of -20°F to 125°F.

4.3. Materials used are deemed equivalent to preservative treated or naturally durable wood for resistance to weathering effects, decay, and attack from termites.

4.4. The *TAM-RAIL*[®] concrete post mount system and adhesive anchor design was evaluated in accordance with AC174 Section 5.1 and ACI 318-08 respectively.

4.5. The tri-layered material utilized in the *TAM-RAIL*[®] Railing System has a flame spread index of 35 when tested according to ASTM E 84. The referenced criteria within ICC-ES AC174, requires a flame spread index not exceeding 200 when tested in accordance with ASTM E 84.

5.0 Installation

The railing system shall be installed in accordance with the manufacturer's installation instructions and this report. Where differences occur between this report and the manufacturer's installation instructions, this report shall govern.

5.1. The balusters are supplied in lengths indicated in Figure 2 based on a two inch clearance between the bottom rail and the walking surface. Balusters are inserted into pre-routed holes in the top and bottom rails. Balusters are not fastened to either the top or bottom rail.

5.2. Stainless Steel (SST) brackets (Figures 4 & 5) and, if necessary molded PVC fixed angle adapters (Figure 6), attach each end of the top and bottom rails to the posts. Fasteners used to assemble the brackets and adapters to rails and posts are outlined in the fastening schedule, Table 2 and Figure 7.

5.3. In areas recognized in Table 1, the top and bottom rails are attached to either conventional 4x4 structural wood posts or a *TAM-RAIL*[®] post mount system each sleeved with a *TAM-RAIL* 4x4 post sleeve. The attachment is made using the brackets shown in Figures 4, 5 and 6 and the fasteners noted in the fastener schedule Table 2 and Figure 7.

5.4. The crush block is cut to a length equal to the desired distance of the lower rail above the walking surface plus 3.25". For the 6' and 8' systems, a single crush block is installed in the pre-routed hole approximately centered in the bottom face of the lower rail. For the 10 ft system, two crush blocks are installed approximately equally spaced in pre-routed holes of the lower rail.

5.5. Railing systems may be attached to conventional wood posts or other suitable wood structure. The wood in the supporting structure shall have a specific gravity of 0.50 or greater (Southern Yellow Pine or better) and a minimum thickness to allow full penetration of the bracket mounting screws. Conventional wood posts or other wood supports are not within the scope of this report.

5.6. Non-structural *TAM-RAIL*[®] post trim ring may be installed at the base of the 4x4 post sleeve or post mount system. The *TAM-RAIL*[®] post cap shall be installed over the exposed end of the post sleeve after installing the sleeve over a 4x4 wood post or a post mount.

5.7. Non-structural *TAM-RAIL*[®] bracket covers may be placed over the top and bottom rails before installation of the rail to the SST mounting bracket. After installation of the rail to the post, the bracket covers are pushed back to the post to cover the SST mounting brackets and hardware.

5.8. The *TAM-RAIL*[®] concrete post mount system must be installed in accordance with the post mount instructions for concrete application supplied by the manufacturer, within the limitations outlined in Section 7.0 of this CCRR and the requirements of ICC-ES ESR-2322. See Figures 9 thru 11.

5.8.1. Special installation instructions are outlined in Section 7.3.

6.0 Supporting Evidence

6.1. Drawings and installation instructions submitted by the manufacturer.

6.2. The reports of testing and engineering analysis demonstrating compliance with the performance requirements of ICC-ES Acceptance Criteria for Deck Board Span Ratings and Guardrail Systems (Guards and Handrails), AC174 effective June 1, 2009 and ASTM D7032-07, Standard Specification for Establishing Performance Ratings for Wood-Plastic Composite Deck Boards and Guardrail Systems (Guards and Handrails).

6.3. The *TAM-RAIL*[®] concrete post mount system was tested in accordance to ICC-ES AC174, Acceptance Criteria for Deck Board Span Ratings and Guardrail Systems (Guards and Handrails), effective June 1, 2009.

6.4. The calculations and engineering analysis of the concrete anchor capacity, under limitation defined in Section 7.0, per ICC-ES Evaluation Report, ESR-2322 for Hilti Inc. HIT-RE 500-SD Adhesive Anchors in Concrete and compliance with ACI 318-08.

6.5. A quality control manual that is in accordance with the ICC-ES AC10, "Acceptance Criteria for Quality Documentation" effective March 1, 2009.

7.0 Conditions of Use

The railing system identified in this report is deemed to comply with the intent of the provisions of the referenced building codes subject to the following conditions.

7.1. Conventional wood supports for guards, including posts, are not within the scope of this report and are subject to evaluation and approval by the building official. Supports must satisfy the design load requirements specified in Chapter 16 of the IBC and FBC and must provide suitable material for anchorage of the rail brackets. Where required by the building official, engineering calculations and details shall be provided.

7.2. For wood composite decking systems, anchors and anchoring systems for use with the *TAM-RAIL*[®] post mount system are not within the scope of this report and are subject to evaluation and approval by the building official. Anchors must satisfy the design load requirements specified in Chapter 16 of the building code and must meet the following minimum requirements;

7.2.1. A minimum of four anchor bolts must be used and located in the four pre-drilled holes in the post base plate.

7.2.2. The anchors must be stainless steel, galvanized steel or other approved material compatible with the steel post mount system.

7.2.3. The anchor bolts must have a minimum diameter of 3/8" and utilize flat washers. The type and length of the anchor bolts is dependent upon the material and condition of the supporting structure and is not within the scope of this report.

7.2.4. When the supporting structure is a wood framed deck, installation must include anchorage to suitable structural framing. Decking is not considered structural framing and anchorage to decking alone is not an approved installation method.

7.2.5. Where required by the building official, engineering calculations and details shall be provided. The calculations shall verify that the anchorage complies with the building codes for the type and condition of the supporting construction.

7.3. For installations utilizing the *TAM-RAIL*[®] concrete post mount system, the following conditions must be met in order to be within the scope of this report.

7.3.1. Installation of the concrete post mount system requires the use of Hilti HIT-RE 500-SD Adhesive Anchoring System as described in ICC-ES ESR-2322.

7.3.2. Installation of the Hilti HIT-RE 500 SD adhesive anchoring system shall be in accordance with ICC-ES ESR-2322. The recognition of the Hilti HIT-RE 500 SD adhesive anchoring system as an approved element of the TAM-RAIL[®] Concrete Post Mount Kits is contingent on the maintenance of a valid ICC-ES ESR-2322 report.

7.3.3. Installation of adhesive anchors must comply with the conditions of use in ICC-ES ESR-2322, unless stated otherwise in this report

7.3.4. **Periodic Special Inspection and Jobsite Quality Assurance** must be provided in accordance with Sections 4.4 of ICC-ES ESR-2322.

7.3.5. Only those fasteners and anchors included with the TAM-RAIL[®] Post Mount Kits and bearing the CCRR-0118 certification label shall be used in the installation. The installation must utilize the 5.5" square concrete adapter plates provided with the concrete mounting kit. See figure 11.

7.3.6. The scope of this CCRR is limited to Installation in dry, cracked and uncracked, normal weight concrete with specified compressive strength of 2,500 to 8,500 psi.

7.3.7. In service concrete temperature must be per Range A of Table 9 in ESR-2322. Max short term temperature = 110 deg F, Max long term temperature = 80 deg F.

7.3.8. Bored holes for installation of the Hilti HIT-RE 500 SD Adhesive anchoring system and 3/8" dia anchor rods must meet the following requirements;

7.3.8.1. Holes shall be located to assure a minimum distance of 4.25" from the edge of the mounting plate to any edge of the concrete. See Figure 9.

7.3.8.2. Holes shall be prepared and cleaned as described in ICC-ES ESR-2322 prior to installation of the anchoring system.

7.3.8.3. Holes shall be drilled using a hammer drill with ANSI B212-1994 approved 7/16" carbide bit.

7.3.8.4. For a 36" high guard system, the hole depth shall be 3.5 inches in concrete having a minimum uniform thickness of 4.75 inches.

7.3.8.5. For a 42" high guard system the hole depth shall be 4 inches in concrete having a minimum uniform thickness of 5 inches.

7.3.8.6. The minimum concrete thickness specified for anchor installation in 7.3.8.4 and 7.3.8.5 refers to a uniform concrete slab and is not applicable to thickness of concrete on a metal deck.

7.3.9. Preparation, application and curing of the Hilti HIT-RE 500 SD adhesive anchoring system shall be as described in ICC-ES ESR-2322 before installing the TAM-RAIL[®] Post Mount concrete adapter plate.

7.3.10. The applied torques to the installed and cured concrete anchors shall not exceed limits established by ICC-ES ESR-2322.

7.3.11. Upon installation of the TAM-RAIL[®] Post Mount, the 3/8" x 2" hex bolts shall be tightened to 33 ft-lbs.

7.3.12. Installation must be in structures assigned to Seismic Design Categories A and B as defined in the referenced codes.

7.3.13. Installations shall not be subject to fatigue or shock loading.

7.4. TAM-RAIL[®] Railing System and post mount system are recognized to the IBC, FBC and IRC for exterior use under the limitations noted in Table 1.

7.5. Only those types of fasteners and fastening methods described in this report have been evaluated for installation of the TAM-RAIL[®] Railing System; other methods of attachment are outside the scope of this report.

7.6. Compatibility of fasteners and other metallic components with the supporting structure, including chemically treated wood, is not within the scope of this report.

7.7. The TAMKO TAM-RAIL[®] Railing System is manufactured in Chilhowie, Virginia and Lamar Missouri, by TAMKO Building Products, Inc. in accordance with the manufacturer's approved quality control system with inspections by PFS Corporation (AA-652).

7.8. For Installations not consistent with the requirements and limitations noted above and in this report, calculations and details demonstrating compliance must be prepared by a licensed Professional Engineer and submitted to the building official having jurisdiction in that area. Otherwise, this installation could be improper and create a safety hazard.

8.0 Identification

The *TAM-RAIL*® Railing System produced by TAMKO Building Products, Inc. identified in this report, shall be identified with labeling on the individual components or the packaging and include the following;

8.1. Name and/or trademark of the manufacturer and the manufacturer's address.

8.2. The identifying mark of the independent inspection agency, PFS Corporation (AA-652).

8.3. The ATI Code Compliance Research Report mark and number (CCRR-0118) and the following statement:

"See CCRR-0118 at www.ati-es.com for uses and performance levels"

9.0 Code Compliance Research Report Use

9.1. Approval of building products and/or materials can only be granted by a building official having legal authority in the specific jurisdiction where approval is sought.

9.2. Code Compliance Research Reports shall not be used in any manner that implies an endorsement of the product by ATI.

9.3. Reference to the Architectural Testing internet web site address at www.archtest.com is recommended to ascertain the current version and status of this report.

Table 1
TAM-RAIL® Guardrail System Building Code Recognition

TAM-RAIL® Guardrail System		Minimum Installed Guardrail Heights ⁽¹⁾	Maximum Installed Span ^{(2) (3)}	
			IBC FBC (Building)	IRC FBC (Residential)
TAM-RAIL® with 4X4 conventional wood post and Tam-Rail® post sleeve.	Level ⁽⁴⁾	36"	120" (limited) ⁽⁵⁾	120"
		42"	120"	120"
	Stair	34"	100" (limited) ⁽⁶⁾	100"
		42"	100"	100"
TAM-RAIL® with TAM-RAIL® post mount system for wood/composite decks, PVC guides and TAM-RAIL® post sleeve	Level ⁽⁴⁾	36"	120" (limited) ⁽⁵⁾	120"
		42"	94"	94"
	Stair	34"	100" (limited) ⁽⁶⁾	100"
		42"	100"	100"
TAM-RAIL® with TAM-RAIL® concrete post mount system, PVC guides and TAM-RAIL® post sleeve	Level ⁽⁴⁾	36"	72" (limited) ⁽⁵⁾	72"
		42"	72"	
		42"	72"	

¹ Guardrail heights are measured vertically above leading edge of stair tread, or adjacent walking surface.

² Guardrail spans are measured between posts along upper rail.

³ Any level TAM-RAIL® Guardrail System greater than 94" in length must utilize the aluminum stiffener inside the upper rail, See Figure 1.

⁴ System may utilize stainless steel brackets and, if necessary, 22.5° and 45° fixed PVC angle adapters. See Table 2 and Figure 7 for approved fasteners.

⁵ Limits to the following conditions;

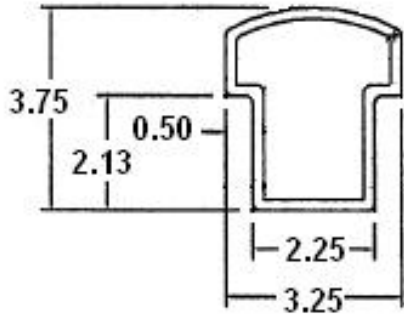
- Detached one- and two-family dwellings and multiple single-family dwellings (townhouses) not more than three stories above grade in height with a separate means of egress
- Residential use Group R-3 adult and child care facilities that are within a single-family home
- Residential use Group R-4 and the building is protected by an automatic sprinkler system

⁶ Guards may be installed at height indicated for occupancies in Residential Group R-3.

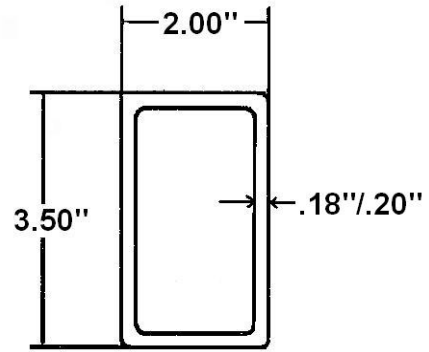


**Table 2
Rail/Bracket Fastening Schedule**

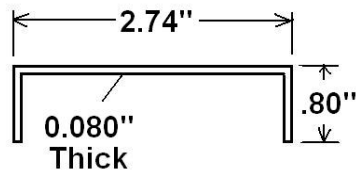
Post	Bracket	Rail	SST Bracket to Rail	SST Bracket to Post
4 X 4 Structural Wood Post and TAM-RAIL® Composite Post Sleeve	SST Brackets	Top Rail	(4) #10 x 1", 8 TPI, Flat-head, Type 17 point, SST Screws	(4) #10 x 2", 8 TPI, Flat-head, Type 17 point, SST Screws
		Bottom Rail	(2) #10 x 1", 8 TPI, Flat-head, Type 17 point, SST Screws	(2) #10 x 2", 8 TPI, Flat-head, Type 17 point, SST Screws
	22.5° and 45° PVC Angle Brackets	Top Rail	(4) #10 x 1", 8 TPI, Flat-head, Type 17 point, SST Screws	(4) #10 x 2", 8 TPI, Flat-head, Type 17 point, SST Screws
		Bottom Rail	(2) #10 x 1", 8 TPI, Flat-head, Type 17 point, SST Screws	(2) #10 x 2", 8 TPI, Flat-head, Type 17 point, SST Screws
TAM-RAIL Post Mount System and TAM-RAIL® Composite Post Sleeve	SST Brackets	Top Rail	(4) #10 x 1", 8 TPI, Flat-head, Type 17 point, SST Screws	(4) #10 x 1", 8 TPI, Flat-head, Type 17 point, SST Screws
		Bottom Rail	(2) #10 x 1", 8 TPI, Flat-head, Type 17 point, SST Screws	(2) #10 x 1", 8 TPI, Flat-head, Type 17 point, SST Screws
	22.5° PVC Angle Brackets	Top Rail	(4) #10 x 1", 8 TPI, Flat-head, Type 17 point, SST Screws	(2) #10 x 1.75", 8 TPI, Flat-head, Type 17 point, SST Screws (See Figure 7)
				(2) #10 x 3", 16 TPI, Flat-head, self-drilling SST Screws penetrating through to steel post (See Figure 7)
	45° PVC Angle Brackets	Bottom Rail	(2) #10 x 1", 8 TPI, Flat-head, Type 17 point, SST Screws	(2) #10 x 1.75", 8 TPI, Flat-head, Type 17 point, SST Screws
		Top Rail	(4) #10 x 1", 8 TPI, Flat-head, Type 17 point, SST Screws	(4) #10 x 2", 8 TPI, Flat-head, Type 17 point SST Screws
Bottom Rail	(2) #10 x 1", 8 TPI Flat-head, Type 17 point SST Screws	(2) #10 x 2", 8 TPI, Flat-head, Type 17 point, SST Screws		



Upper T-Rail ⁽¹⁾



Bottom Rail ⁽¹⁾



**Top Rail Aluminum Stiffener
For Rail Lengths Exceeding 94 Inches**

**Figure 1
TAM-RAIL[®] Rail Cross Sections
⁽¹⁾ Rails are pre-routed for balusters**

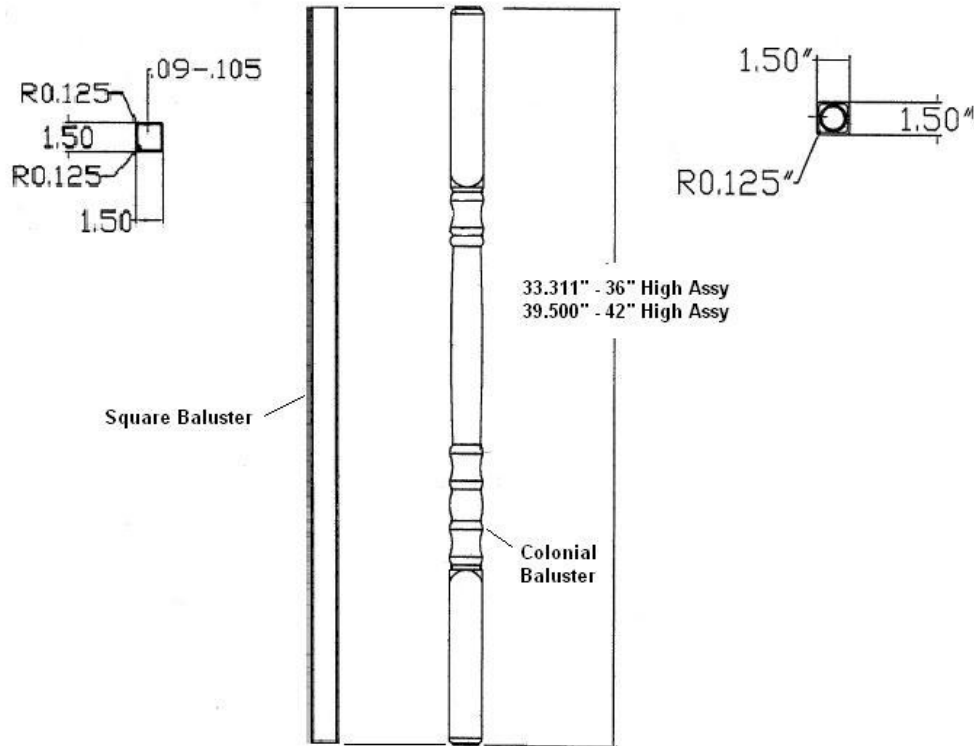


Figure 2
TAM-RAIL® Baluster Configurations

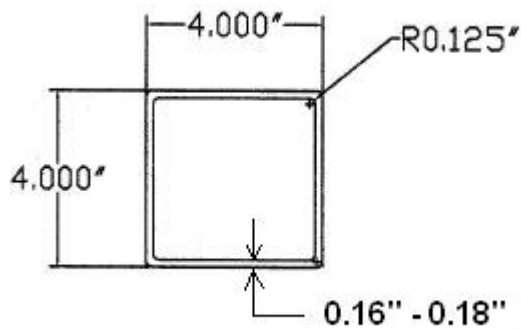


Figure 3
TAM-RAIL® 4x4 Post Sleeve Cross Section

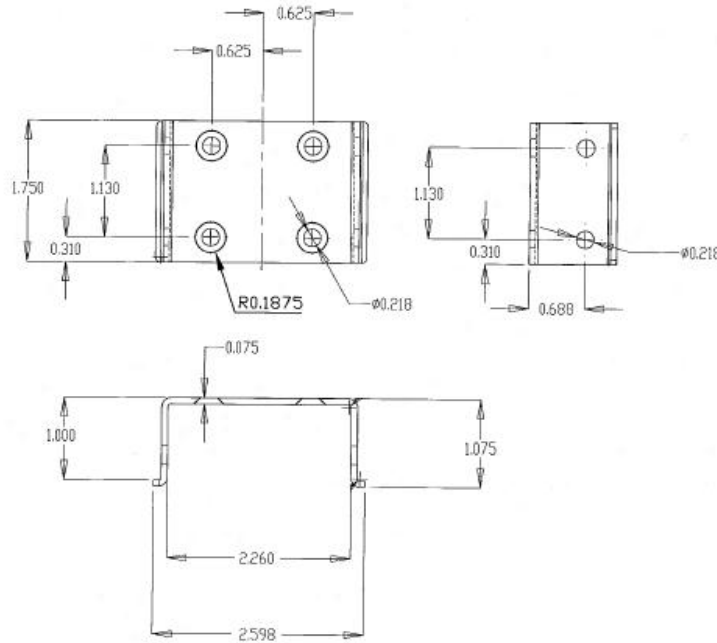


Figure 4
TAM RAIL® -Upper Attachment Bracket (SST)

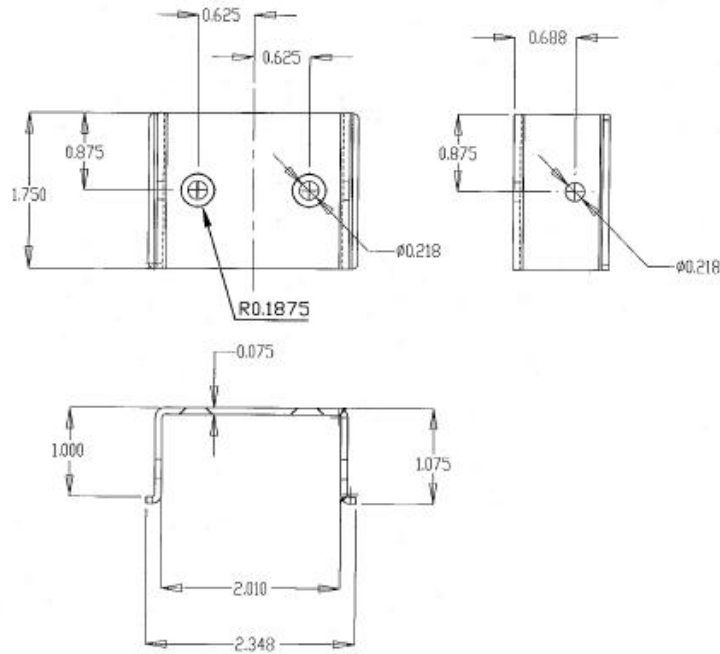
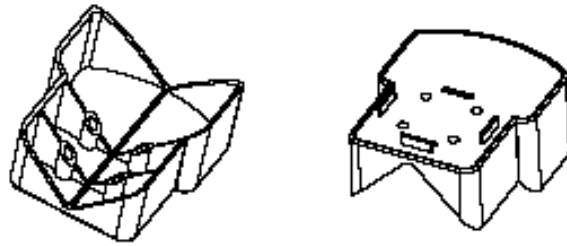
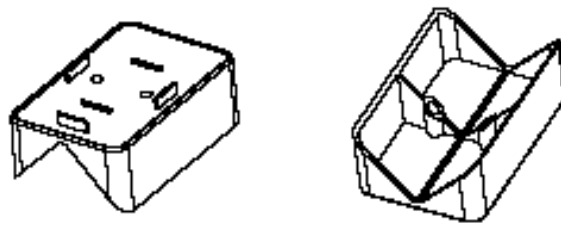


Figure 5
TAM-RAIL® -Lower Attachment Bracket (SST)



Upper Rail 45° PVC Bracket



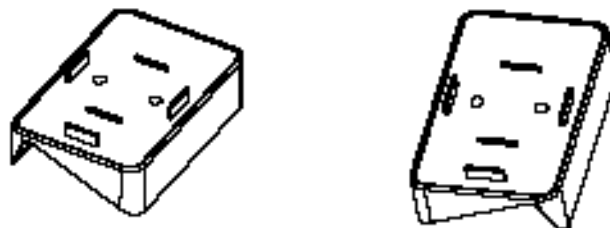
Lower Rail 45° PVC Bracket



Left 22.5° Bracket

Right 22.5° Bracket

Upper Rail 22.5° PVC Bracket



Left 22.5° Bracket

Right 22.5° Bracket

Lower Rail 22.5° PVC Bracket

Figure 6
TAM-RAIL® -PVC Fixed Angle Adapters (22.5° and 45°)

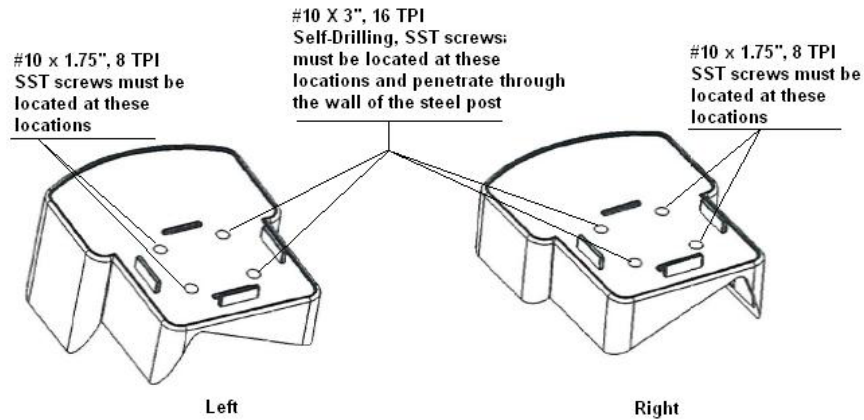


Figure 7
Screw Assembly Locations for TAM-RAIL® 22.5° Fixed Angle Adapter
 (See Table 2)

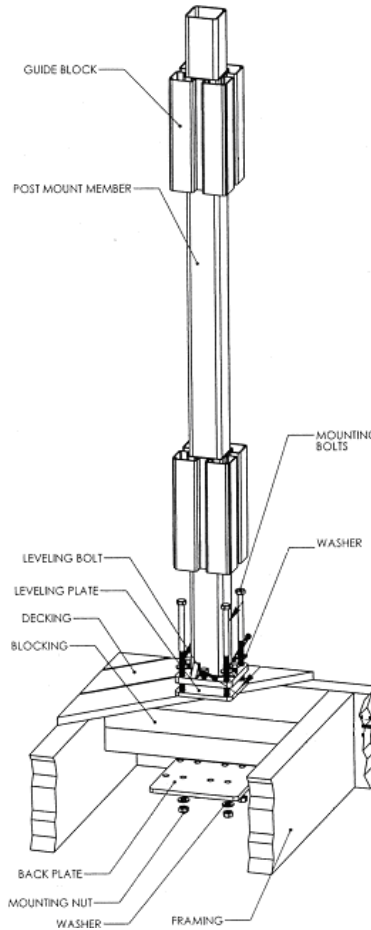


Figure 8
TAM-RAIL® Post Mount System with PVC Guides
Wood/Composite Deck Installation

Note: supporting structure (wood deck or concrete) is not within the scope of this report and must be designed and constructed in accordance with Chapter 16 of the IBC and FBC. Refer to Section 7.2.

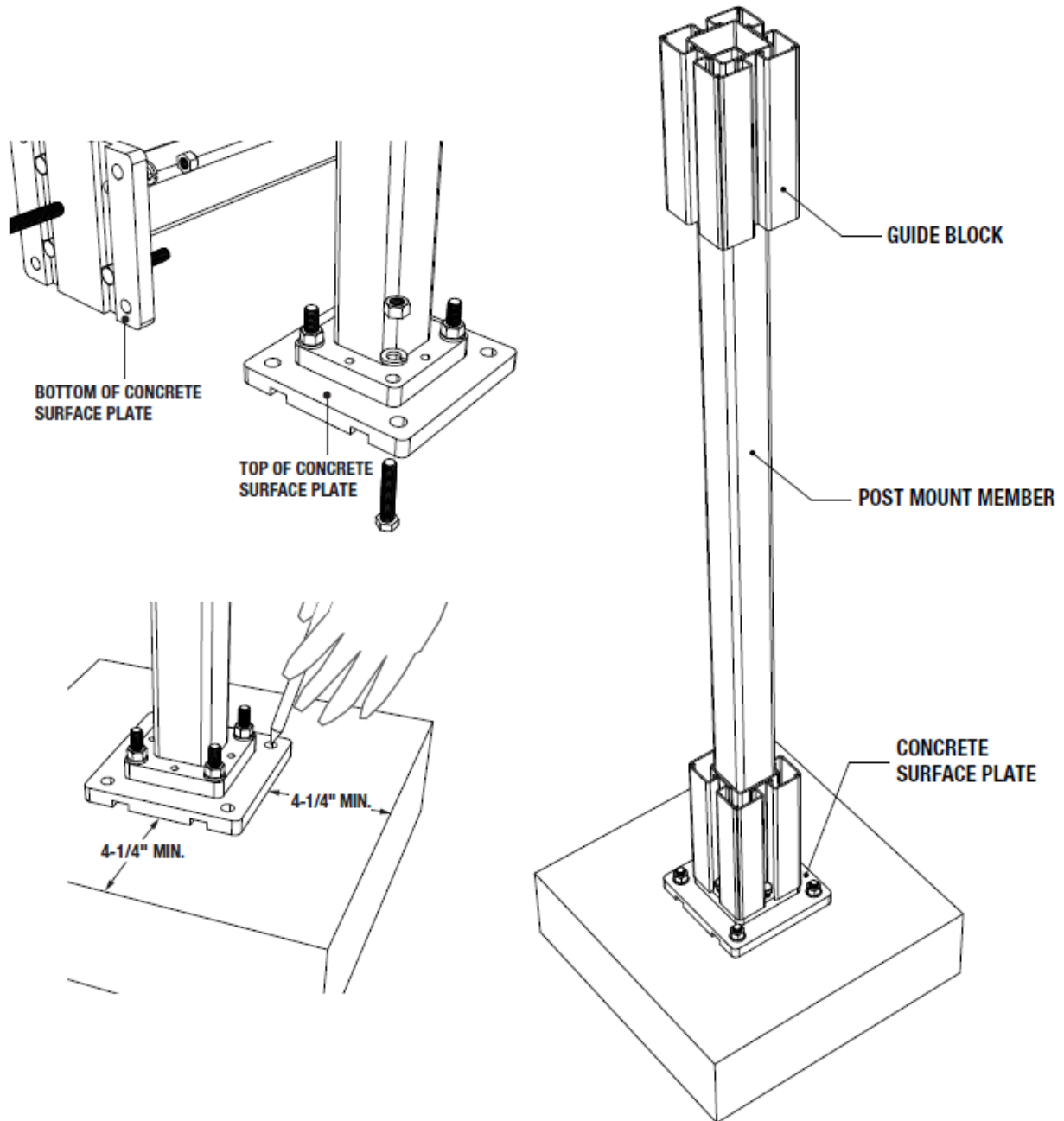


Figure 9
TAM-RAIL[®] Concrete Post Mount System with PVC Guides

Note: supporting structure (wood deck or concrete) is not within the scope of this report and must be designed and constructed in accordance with Chapter 16 of the IBC and FBC. Refer to Section 7.2.

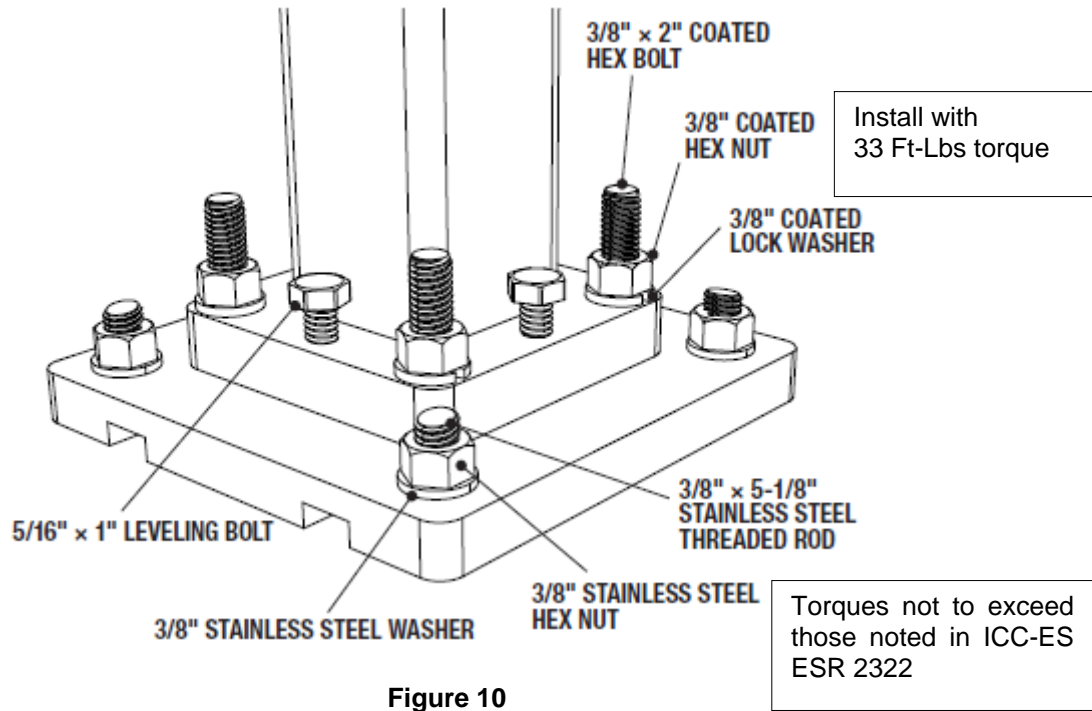


Figure 10
Concrete Surface Plate Fasteners

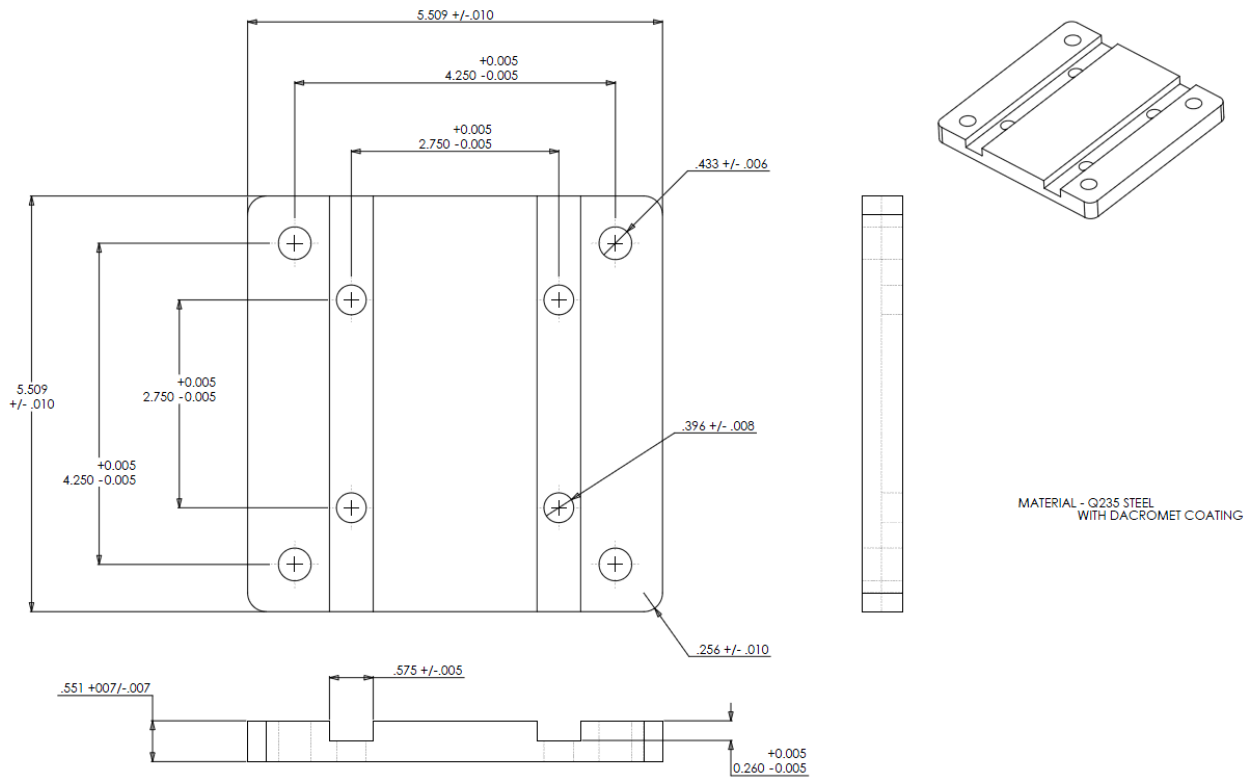


Figure 11
TAM-RAIL® Concrete Surface Plate