

TAMKO® TW UNDERLAYMENT

Self-Adhering Roofing Underlayment

PRODUCT DATA

DESCRIPTION

TAMKO® TW UNDERLAYMENT is a flexible, self-adhering rubberized asphalt sheet membrane with a polymer film on the surface and a removable treated release film on the adhesive side.

USES

TAMKO TW UNDERLAYMENT is well suited for use as an underlayment where prevention of water penetration is required including under metal roofs*. TW Underlayment also provides secondary protection against water penetration after installation of the roof system. When fasteners penetrate the TW Underlayment membrane during installation of a metal roof system, the metal roof system manufacturer's recommendations should be followed to assure watertight integrity at the fastener penetrations.

*Before installing TW Underlayment under copper roofing, a design professional must be consulted to analyze the interaction of the building, roof deck, and roof assembly with regards to adequate temperature resistance.

ADVANTAGES

- Textured surface provides enhanced skid resistance.
- Adheres to cast-in-place concrete, pre-cast concrete masonry block, exterior gypsum sheathing, plywood, OSB, DensGlass®, DensGlass Gold®, felt-faced and foil-faced polyisocyanurate foam insulation, wood or metal surfaces**.
- Treated release film for easier installation.
- High temperature resistance up to 245° F.
- Can be left exposed for up to 90 days before application of finished roof.
- ICC-ES ESR-1252.
- Florida Building Code Approval # FL 3664.

**TAMKO recommends if the low expected temperature average for the scheduled application period is 65°F or lower TW Underlayment Winter Grade should be used.

LIMITATIONS

- Membrane or primer must not be applied to damp, frosty or contaminated surfaces.
- Membrane must not come into contact with products containing coal-tar pitch.
- Must be applied at temperatures of 40° F and higher.

PRODUCT DATA***

	2 Square
Roll Size	200 sq. ft.
Roll Dimensions	39-3/8" x 61'
Thickness	40 mil
Rolls Per Pallet	
48" x 36"	24 rolls

***All values stated as nominal.

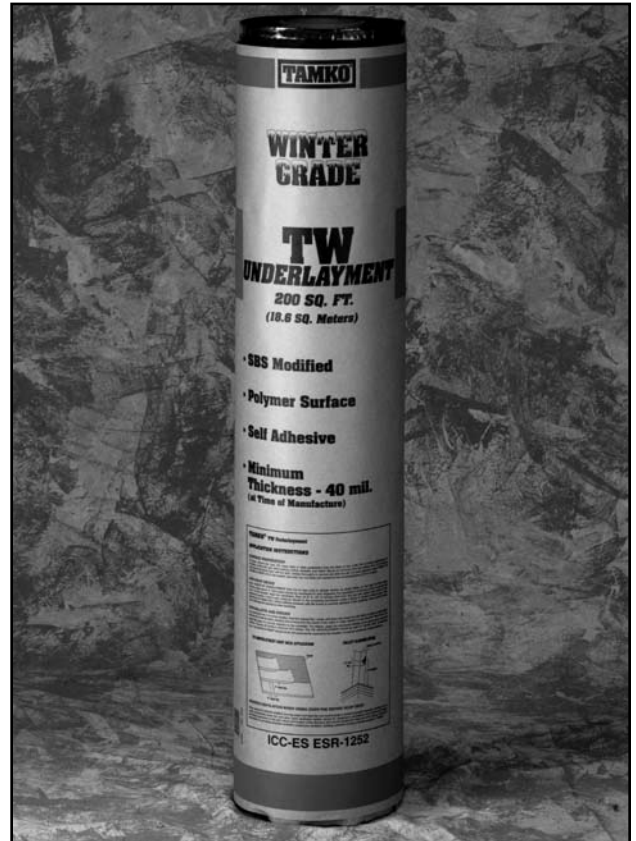

TYPICAL PHYSICAL PROPERTIES

Property	Test Method	Typical Value
Adhesion to Plywood	ASTM D 903	12.0 lbf/in width
Moisture Vapor Permeability	ASTM E 96 (BW)	0.05 perms (max)
Air Permeance ($\Delta P = 75$ Pa)	ASTM E 2178	<0.0003 L/s-m ² (<0.0000 CFM/ft ²)
Maximum Load	ASTM D 1970	30 lbf/in
Elongation Modified Bitumin Portion	ASTM D 1970	125%
Tear Resistance	ASTM D 1970	40 lbf
Low Temperature Flexibility	ASTM D 1970 (modified) ¹	-15° F

¹ Testing done using procedures in ASTM D 1970 with adhesive side away from the mandrel.

CAUTION: This product contains crystalline silica and formaldehyde. Crystalline silica and formaldehyde have been classified as "known" human carcinogens by the International Agency for Research on Cancer and the National Toxicology Program. This product contains asphalt. The National Institute for Occupational Safety and Health has concluded that the fumes of heated roofing asphalt are a potential occupational carcinogen. The physical nature of this product may help limit any inhalation or dermal hazard during application and/or removal. However, physical forces such as sawing, grinding or drilling during demolition work and heating or burning may increase the inhalation or dermal exposure hazard of this product. Take precautions to prevent breathing and contact with skin.

TAMKO®
BUILDING PRODUCTS

TAMKO® TW Underlayment

APPLICATION INSTRUCTIONS

SURFACE PREPARATION

To begin, remove any dust, dirt, loose nails or other protrusions from the deck of new roofs. Remove all shingles, roofing felt, nails, or other existing roofing materials and debris from the deck of existing roofs. Sweep thoroughly to remove any dust and dirt. Apply TW UNDERLAYMENT only in fair weather and when air, substrate, and membrane are at temperatures of 40° F or higher. Primer is generally not required for surfaces that are smooth, clean, and dry. In any case where adhesion is found to be marginal, prime with TAMKO TWP-1 or TWP-2 primers at the designated coverage rates. Priming is always required when adhering to concrete.

FOR ROOF DECKS

Apply TAMKO TW UNDERLAYMENT from low to high point in shingle fashion as shown below, so that laps will shed water. Overlap edge seams 4". End seams should be overlapped 6" and staggered. Where necessary, the membrane may be unrolled and cut into 10-to 15-foot lengths. Align the membrane. Peel off 6" to 12" of release film from one end and adhere that portion of the membrane using a heavy hand pressure. Broom in the remaining membrane, using a heavy to medium bristle broom, while removing the release film. Utilize sufficient pressure with the broom to promote adhesion to the substrate. Care must be taken not to damage the membrane when brooming.

FOR VALLEYS AND RIDGES

Where necessary, the membrane may be unrolled and cut into 4- to 6-foot lengths. Peel the release film, center and drape the sheet over the valley or ridge as appropriate. Adhere the sheet by hand, pressing and working from the center of the valley or ridge outward in each direction, then broom the sheet into place to promote the adherence to the substrate. For valleys, apply the membrane starting at the lowest point and work upward. Overlap all sheets a minimum of 6 inches. The TW UNDERLAYMENT should be used on "closed valley" applications only. TW UNDERLAYMENT should not be left permanently exposed to the weather. It must be covered by roofing materials.

TW UNDERLAYMENT FIELD APPLICATION

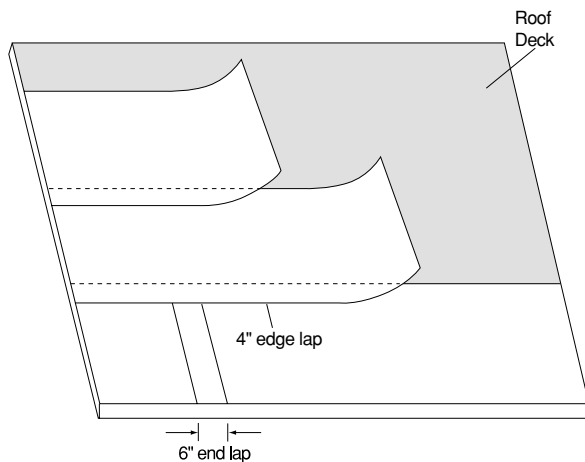

VALLEY FLASHING DETAIL

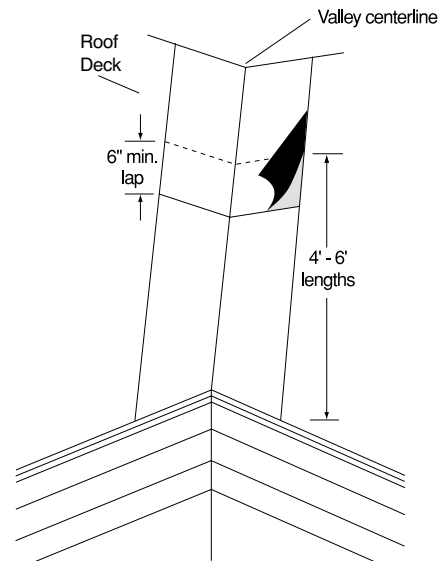

APPLICATION WITH ROLL LENGTH PARALLEL TO THE ROOF SLOPE

TAMKO TW Underlayment may be applied with the long dimension of the roll running parallel to the roof slope in situations where the roof slope equals or exceeds 21 inches per foot. In these applications, side laps must be a minimum of 4" wide and formed so the smooth film selvage along one side of the roll is covered by the adjacent roll of TW Underlayment. All side and end laps must be rolled with a roofing seam roller in addition to brooming the entire surface.

VENTILATION

A vapor retarding layer may result when TW Underlayment is installed over an entire roof deck. Design of the entire roof system and the area immediately beneath the roof deck (e.g. attic, plenum, conditioned space) to properly address potential moisture and heat accumulation is the responsibility of design professional (e.g. architect, engineer) and the building owner. Specific ventilation requirements expressed in applicable building codes or necessitated by the roof covering may apply and should be considered.

TAMKO® TW Underlayment

APPLICATION INSTRUCTIONS (CONTINUED)

REPAIRING MINOR DAMAGE TO TW UNDERLAYMENT

Patch repair: Minor damaged areas of TAMKO TW Underlayment that are no longer than 4" by 4" in size (e.g. tears, holes, fishmouths and delaminations) can be repaired by installing a patch of TW Underlayment extending a minimum of 12" beyond the damaged area on all sides.

End Lap Repair: Loose end laps no wider than 4" can be repaired by cutting and removing the loose material and applying a patch that extends 12" beyond the area on all sides. Limitations stated previously in this Product Data Sheet still apply when conducting repairs.

A Patch Repair or an End Lap Repair must begin with removal of dust, dirt and other materials that may interfere with adhesion from the area receiving the patch. Sweep the area to receive the patch with a stiff nylon bristle broom, making sure all loose material is removed from the area to receive the patch. Remove or cut non-adhered, torn or otherwise damaged membrane as necessary, creating a fully-adhered surface to receive the patch. The underlying substrate must not be damaged while performing a Patch Repair or an End Lap Repair.

In areas where available, prime the entire area receiving that patch with TAMKO TWP-1 Quick Dry Primer at the recommended application rate to enhance adhesion (refer to the TWP-1 Quick Dry Primer Product Data Sheet). Allow the primer to cure prior to installation of the TW Underlayment patch.

Install the TW Underlayment patch. Apply sufficient pressure using a broom or roofing seam roller to promote adhesion to the underlying material. Seal the edges of the patch by applying a bead of compatible polyurethane sealant; smooth the bead with a trowel. Select a sealant suitable for use with rubberized asphalt per the sealant manufacturer's written application instructions.

Information included in this product data sheet was current at time of printing. To obtain a copy of the most current version of this product data sheet, visit us online at tamko.com or call us at 800-641-4691.

This product is covered by a 5-year limited warranty. For information regarding or a copy of TAMKO's limited warranty, contact your local TAMKO representative, visit us online at tamko.com, or call us at 800-641-4691.

tamko.com

Corporate	220 West 4th Street, Joplin, Missouri 64801	800-641-4691
Central District	220 West 4th Street, Joplin, Missouri 64801	800-641-4691
Northeast District	4500 Tamko Drive, Frederick, Maryland 21701	800-368-2055
Southeast District	2300 35th Street, Tuscaloosa, Alabama 35401	800-228-2656
Southwest District	7910 South Central Expressway, Dallas, Texas 75216	800-443-1834
Western District	5300 East 43rd Avenue, Denver, Colorado 80216	800-530-8868

©2012 TAMKO Building Products, Inc. TAMKO® is a registered trademark of TAMKO Building Products, Inc.

