

UL Evaluation Report

UL ER2919-01

Issued: May 21, 2013

Revised: September 15, 2017

Visit UL's On-Line Certifications Directory: www.ul.com/erdirectory
for current status of Report.

UL Category Code: ULEZ

CSI MasterFormat®

DIVISION: 07 00 00 – THERMAL AND MOISTURE PROTECTION
Sub-level 2: 07 30 00 – Steep Slope Roofing
Sub-level 3: 07 31 00 – Shingles and Shakes
Sub-level 4: 07 31 13 – Asphalt Shingles

COMPANY:

TAMKO BUILDING PRODUCTS, INC.
220 WEST FOURTH STREET
JOPLIN, MISSOURI 64802
(417) 624-6644
www.tamko.com

1. SUBJECT: Asphalt Shingles

GLASS-SEAL, ELITE GLASS-SEAL

HERITAGE, HERITAGE PREMIUM, HERITAGE WOODGATE, HERITAGE VINTAGE,

HERITAGE VINTAGE 12 X 12 HIP AND RIDGE, 12-¹/₄ X 12 HIP AND RIDGE.

2. SCOPE OF EVALUATION

- 2006, 2009, 2012 and 2015 *International Building Code*® (IBC)
- 2006, 2009, 2012 and 2015 *International Residential Code*® (IRC)
- ICC ES Acceptance Criteria for Quality Documentation (AC10), Dated June 2014



The products were evaluated for the following properties:

- Exterior Fire Exposure (ANSI/UL790, ASTM E108)
- Wind Resistance (ASTM D3161; ASTM D7158)
- Physical Properties (ASTM D3462)

3. REFERENCED DOCUMENTS

- ANSI/UL790 (ASTM E108), Standard Test Methods for Fire Tests of Roof Coverings
- ASTM D3161, Standard Test Method for Wind-Resistance of Asphalt Shingles (Fan-Induced Method)
- ASTM D7158, Standard Test Method for Wind Resistance of Asphalt Shingles (Uplift Force/Uplift Resistance Method)
- ASTM D3462, Standard Specification for Asphalt Shingles Made from Glass Felt and Surfaced with Mineral Granules
- UL Subject 2375, Outline of Investigation for Hip and Ridge Shingles (UL Fire and Wind Tests)
- ICC-ES Acceptance Criteria for Quality Documentation (AC10), Dated June 2014

4. USES

TAMKO asphalt shingles are used as roof coverings for new and existing roofs.

5. PRODUCT DESCRIPTION

TAMKO asphalt shingles are roof covering materials complying with the following properties when installed as described in this report. The products are three-tab shingles, laminated shingles and hip & ridge shingles. The products are available in standard and metric sizes.

Fire Classification: TAMKO asphalt shingles covered under this Report have been tested for fire classification Class A in accordance with UL 790 (ASTM E108). Shingles tested in accordance with UL790 (ASTM E108) qualify for use under [Section 1505.1](#) of the 2015, 2012, 2009 and 2006 IBC and [Section R902.1](#) of the 2015, 2012, 2009 and 2006 IRC.

Wind Resistance: TAMKO asphalt shingles covered under this Report have been tested for wind resistance in accordance with ASTM D3161 or ASTM D7158.

Shingles tested in accordance with ASTM D3161 are classified as Class F or Class A and qualify for use under the exception to [Section 1507.2.7.1](#) of the 2015, 2012, 2009 and 2006 IBC, or the exception to [Section R905.2.4.1](#) of the 2015, 2012, 2009 and 2006 IRC.

Shingles tested in accordance with ASTM D7158 are classified as Class H and qualify for use in locations as shown in [Table 1507.2.7.1](#) of the 2012 and 2009 IBC or [Table R905.2.4.1](#) of the 2012 and 2009 IRC, where the maximum basic wind speed is 150 mph (67 m/s) or less with exposure category of B or C (ASCE 7) and a maximum building height of 60 feet (18.3 m). Installation must be in accordance with [Section 1507.2.7](#) of the 2015, 2012, 2009 and 2006 IBC, or [Section R905.2.6](#) of the 2015, 2012, 2009 and 2006 IRC, as applicable.

Physical Properties: TAMKO asphalt shingles covered under this Report have been tested for physical properties in accordance with ASTM D3462. Shingles tested in accordance with ASTM D3462 qualify for use under [Section 1507.2.5](#) of the 2015, 2012, 2009 and 2006 IBC or [Section R905.2.4](#) of the 2015, 2012, 2009 and 2006 IRC. When installed on new construction in accordance with this report and the TAMKO Building Products, Inc. installation instructions, the shingles are a Class A roof covering. When the shingles are installed over existing roof coverings, the Class A fire classification is maintained.

5.1 Three-Tab Shingles – Glass-Seal, Elite Glass-Seal:

Glass-Seal and Elite Glass-Seal shingles are three-tab shingles manufactured with a single fiberglass mat, coated on both sides with asphalt, and surfaced on the weather-exposed side with mineral granules. The shingles are self-sealing and have beads of thermal-tab sealing adhesive above the shingle butt on the weather side. See [Table 2](#) and [Table 3](#) for product dimensions and manufacturing locations.

5.2 Laminated Shingles – Heritage, Heritage Premium, Heritage Woodgate, Heritage Vintage:

Heritage, Heritage Premium, Heritage Woodgate and Heritage Vintage shingles are laminated shingles manufactured with a double layer of fiberglass mats coated with asphalt on all sides, and surfaced on the weather-exposed side with mineral granules. See [Table 4](#), [Table 5](#), [Table 6](#), and [Table 7](#) for product dimensions and manufacturing locations.

5.3 Hip & Ridge Shingles – 12-¹/₄ X 12 Hip and Ridge, Heritage Vintage 12 X 12 Hip And Ridge:

Hip and Ridge are prefabricated hip and ridge shingles available as 12-¹/₄ X 12 Hip and Ridge. Heritage Vintage Hip and Ridge are prefabricated hip and ridge shingles available as 12 X 12 Hip and Ridge. As an alternative, Elite Glass-Seal shingles are cut into three 12-¹/₄ inch by 12-inch (305 mm by 305 mm) hip and ridge shingles. See [Table 8](#) and [Table 9](#) for product dimensions and manufacturing locations.

6. INSTALLATION

TAMKO asphalt shingles must be installed in accordance with the applicable code, this report and the manufacturer's published installation instructions. The shingles must be installed in accordance with [Section 1507.2](#) of the 2015, 2012, 2009 and 2006 IBC or [Section R905.2](#) of the 2015, 2012, 2009 and 2006 IRC, as applicable, except as noted in this report.

The manufacturer's published installation instructions must be available at all times on the jobsite during installation.

Minimum roof slopes must be 2:12 (16.67% slope) for the three-tab shingles described under 5.1 of this Report and for the laminated shingles described under 5.2 of this Report.

6.1 Underlayment and Ice Barriers:

For roof slopes greater than 4:12, the roof deck must be covered with a minimum of one layer of underlayment as described in Sections 7.2 and 7.3 of this Report. Underlayment application must be in accordance with [Section 1507.2.8](#) of the 2015, 2012, 2009 and 2006 IBC or [Section R905.2.7](#) of the 2015, 2012, 2009 and 2006 IRC, as applicable.

For roof slopes between 2:12 and 4:12, two layers of the underlayment described in Section 7.2 or one layer of the self-adhering polymer modified bitumen sheet in described in Section 7.3 of this Report are required. Underlayment application must be in accordance with [Section 1507.2.8](#) of the 2015, 2012, 2009 and 2006 IBC or [Section R905.2.7](#) of the 2015, 2012, 2009 and 2006 of the IRC, as applicable.

In areas where there has been a history of ice forming along the eaves, causing a backup of water, an ice barrier must be provided in accordance with [Section 1507.2.8.2](#) of the 2015, 2012, 2009 and 2006 IBC or [Section R905.2.7.1](#) of the 2015, 2012, 2009 and 2006 IRC, as applicable.

6.2 Starter Shingle:

A starter course, as described in Section 7.4 of this Report, must be attached to the eave edge using fasteners described in Section 7.5 of this Report, located 3 to 4 inches (76 to 102 mm) from the eave edge and spaced 1 inch (25.4 mm) and 12 inches (305 mm) from each end, for a total of four fasteners per shingle. The starter strip must overhang the eave and rake edges by ¹/₄ to ³/₈ inch (6.5 to 9.5 mm).

6.3 Asphalt Shingles:

The first course of field shingles must be installed over the starter course described in Section 7.4 of this Report.

Shingles must be installed with vertical joints offset a minimum of 4 inches (102 mm) from adjacent courses.

6.3.1 Three-Tab Shingles – Glass-Seal, Elite Glass-Seal:

For roof slopes of 2:12 up to 21:12 (16.67% to 175% slope), each shingle must be fastened to the roof deck using a minimum of four fasteners, spaced as shown in Tables 2 and 3.

For roof slopes over 21:12 (175% slope), six fasteners must be used, spaced as shown in Tables 2 and 3.

Fasteners must be in a nail area between $5\frac{5}{8}$ inches and $6\frac{7}{8}$ inches from the butt edge of the shingle.

Maximum exposure to the weather must be $5\frac{1}{8}$ inches (130 mm).

In colder climates or wind regions where it is questionable whether the thermal-sealing adhesive will activate to seal the shingles, the shingles can be hand-sealed. A 1-in diameter (25.4 mm) spot of asphalt cement complying with ASTM D4586, Type I, Class I, should be placed under the corner of each tab (two spots per tab).

6.3.2 Laminated Shingles – Heritage, Heritage Premium, Heritage IR, Heritage Woodgate:

For roof slopes of 2:12 up to 21:12 (16.67% to 175% slope), each shingle must be fastened to the roof deck using a minimum of four fasteners, spaced as shown in Tables 4, 5, and 6.

For roof slopes over 21:12 (175% slope), six fasteners must be used, spaced as shown in Tables 4, 5, and 6.

Fasteners must be located $5\frac{1}{2}$ inches (140 mm) or $6\frac{1}{8}$ inches (157 mm) above the butt edge of the shingles.

Maximum exposure to the weather must be 5 inches (127 mm) or $5\frac{5}{8}$ inches (143 mm).

In colder climates or wind regions where it is questionable whether the thermal-sealing adhesive will activate to seal the shingles, the shingles can be hand-sealed. Four evenly spaced 1-inch diameter (25.4 mm) spots of cement should be placed under the exposed portion of the shingle, approximately 1 inch (76 mm) above the butt edge.

6.3.3 Laminated Shingles – Heritage Vintage:

For roof slopes of 2:12 up to 21:12 (16.67% to 175% slope), each shingle must be fastened to the roof deck using a minimum of five fasteners, spaced as shown in Table 7.

For roof slopes over 21:12 (175% slope), nine fasteners must be used, spaced as shown in Table 7.

Fasteners must be located 6 and $11\frac{1}{2}$ inches (152 and 292 mm) above the butt edge of the shingles.

Maximum exposure to the weather must be 5 inches (127 mm).

In colder climates or wind regions where it is questionable whether the thermal-sealing adhesive will activate to seal the shingles, the shingles can be hand-sealed. Four evenly spaced 1-inch diameter (25.4 mm) spots of cement should be placed under the exposed portion of the shingle, approximately 1 inch (127 mm) above the butt edge.

6.4 Valley Construction and Other Flashing:

Valleys must consist of woven, open valley or closed-cut construction and must be flashed in accordance with [Section 1507.2.9.2](#) of the 2015, 2012, 2009 and 2006 IBC or Section R905.2.8.2 of the 2015, 2012, 2009 and 2006 IRC. Other flashings must be in accordance with [Sections 1503.2](#) and [1507.2.9](#) of the 2015, 2012, 2009 and 2006 IBC, or [Section R903.2](#) and [Section R905.2.8](#) of the 2015, 2012, 2009 and 2006 IRC, as applicable.

6.5 Hip and Ridge Application:

Hip and ridge shingles must be placed evenly over hips and ridges, and must be fastened to the roof deck using two fasteners, one located on either side of the shingle, 5-¹/₂ inches (140 mm) or 5-⁵/₈ inches (143 mm) from the exposed end, and 1 inch (25.4 mm) in from the edge as shown in Tables 8 and 9. Fasteners must be ¹/₄ inch (6.4 mm) longer than those used in the field of the roof, as specified in Section 7.5 of this report. The 12-¹/₄ X 12 Hip and Ridge prefabricated hip and ridge shingles must be applied with a maximum exposure of 5-¹/₈ inches. (130 mm). Heritage Vintage 12 X 12 Hip and Ridge prefabricated hip and ridge shingles must be installed with a maximum exposure of 5 inches. (127 mm). Hip and ridge shingles are installed starting at the bottom of the hip or from the end of the ridge opposite the direction of the prevailing wind.

6.6 Reroofing:

The existing asphalt shingle roof covering must be inspected in accordance with the provisions and limitations of [Section 1510](#) of the 2015, 2012, 2009 and 2006 IBC or [Section R907](#) of the 2015, 2012, 2009 and 2006 IRC, as applicable. Prior to the reroofing, hip and ridge coverings must be removed.

Except as noted in this section, the shingles must be installed in accordance with Section 6.3 and 6.5 of this Report. Fasteners must be of sufficient length to penetrate ³/₄ inch (19.1 mm) into the sheathing, or through the sheathing where the sheathing is less than ³/₄ inch (19.1 mm) thick. Flashing and edging must comply with Section 6.4 and with [Sections 1510.5](#) and [1510.6](#) of the 2015, 2012, 2009 and 2006 IBC and [Sections R907.5](#) and [R907.6](#) of the 2015, 2012, 2009 and 2006 IRC, as applicable.

7. INSTALLATION MATERIALS

7.1 Sheathing:

The roof deck must be code-complying, minimum ³/₈-inch thick (9.5 mm), exterior plywood complying with DOC PS-1; rated sheathing complying with DOC PS-2; or solid sheathing using minimum nominally 1 by 6 lumber.

7.2 Underlayment:

Under the IBC or IRC, underlayment must comply with ASTM D226, Type I (minimum), ASTM D4869, Type I (minimum) or ASTM D6757 as specified in [Section 1507.2.3](#) of the 2015, 2012, 2009 and 2006 IBC or [Section R905.2.3](#) of the 2015, 2012, 2009 and 2006 IRC.

7.3 Self-adhering Polymer Modified Bitumen Sheet:

The self-adhering polymer modified bitumen sheet must comply with ASTM D1970.

7.4 Starter Shingles:

The starter course shingle consists of either TAMKO 10-inch starter, TAMKO Shingle Starter, or a self-sealing three-tab shingle. If self-sealing three-tab shingles are used, remove the exposed tab portion and install with factory-applied sealant adjacent to the eaves.

Heritage Vintage requires a Heritage Vintage starter to be installed over the first starter course at the eave edge.

7.5 Fasteners:

Fasteners must be minimum No. 12 gage [0.105 inch (2.7 mm)], $\frac{3}{8}$ -inch diameter head (9.5 mm), galvanized, stainless steel, aluminum or copper corrosion-resistance nails. Fasteners must be of sufficient length to penetrate into the sheathing $\frac{3}{4}$ -inch (19.1 mm), or through the sheathing, where the sheathing is less than $\frac{3}{4}$ -inch (19.1 mm) thick. Fasteners must be compliant with ASTM F1667.

7.6 Asphalt Cement:

Asphalt cement must comply with ASTM D4586, Type I, Class I.

8. CONDITIONS OF USE

The TAMKO Asphalt Shingles described in this Report comply with, or are suitable alternatives to, what is specified in those codes listed in Section 2 of this Report, subject to the following conditions:

- 8.1** Materials and methods of installation shall comply with this Report and the manufacturer's published installation instructions. In the event of a conflict between the installation instructions and this Report, this Report governs.
- 8.2** The products are manufactured at the locations listed in Table 1 of this Report under the UL LLC Classification and Follow-Up Service Program, which includes regular audits in accordance with quality elements of ICC-ES Acceptance Criteria for Quality Documentation, AC10.
- 8.3** See UL Online Certifications Directory Prepared Roof-Covering Materials (TFWZ).

9. SUPPORTING EVIDENCE

- 9.1** Manufacturer's descriptive product literature, including installation instructions.
- 9.2** UL test reports and Classification in accordance with ANSI/UL 790, Class A and UL Subject 2375. See UL Product Certification Category for Prepared Roof-Covering Materials ([TFWZ](#)).
- 9.3** UL test reports and Classification in accordance with ASTM D3462. See UL Product Certification Category for Prepared Roof-Covering Materials ([TFWZ](#)).
- 9.4** UL test reports and Classification in accordance with UL 2390/ASTM D7158, Class H. See UL Product Certification Category for Prepared Roof-Covering Materials ([TGAH](#)).
- 9.5** UL test reports and Classification in accordance with ASTM D3161, Class F. See UL Product Certification Category for Prepared Roof-Covering Materials ([TFWZ](#)).
- 9.6** Quality Documentation in accordance with ICC-ES Acceptance Criteria for Quality Documentation, AC10.

See UL's On-Line Certification Directory for the following product categories referenced above.

10. IDENTIFICATION

TAMKO asphalt shingles described in this Evaluation Report are identified by a marking on each package bearing the report holder's name (TAMKO Building Products, Inc.), the plant identification, the product

name, the UL Listing/Classification Mark and the evaluation report number UL ER2919-01. The validity of this Evaluation Report is contingent upon this identification appearing on the package.

11. USE OF UL EVALUATION REPORT

- 11.1 The approval of building products, materials or systems is under the responsibility of the applicable authorities having jurisdiction.
- 11.2 UL Evaluation Reports shall not be used in any manner that implies an endorsement of the product, material or system by UL.
- 11.3 The current status of this report, as well as a complete directory of UL Evaluation Reports may be found at UL.com via our On-Line Certifications Directory at www.ul.com/erdirectory.

Table 1 – Manufacturing Locations

LISTEE	LOCATION	FACTORY ID
TAMKO BUILDING PRODUCTS INC	7910 S CENTRAL EXPY DALLAS TX 75216	D
TAMKO BUILDING PRODUCTS INC	4500 TAMKO DR FREDERICK MD 21704	F
TAMKO BUILDING PRODUCTS INC	601 N HIGH ST JOPLIN MO 64801	J
TAMKO BUILDING PRODUCTS INC	1598 HWY 183 PHILLIPSBURG KS 67661	P
TAMKO BUILDING PRODUCTS INC	KAUL INDUSTRIAL PARK 2300 35TH ST TUSCALOOSA AL 35401	T

Table 2 – Glass-Seal

Dimensions:	12- ¹ / ₄ " x 36"
Plant Location(s):	Frederick, Joplin, Tuscaloosa
Fastening Pattern:	<p>For slopes of 2:12 up to 21:12</p>  <p>NAILS</p> <p>1" 1"</p> <p>Nailing Area</p> <p>6-7/8"</p> <p>5-5/8"</p> <p>Butt Edge</p>
Fastening Pattern:	<p>For slopes greater than 21:12</p>  <p>NAILS</p> <p>1" 1"</p> <p>Nailing Area</p> <p>6-7/8"</p> <p>5-5/8"</p> <p>Butt Edge</p>

Table 3 – Elite Glass-Seal

Dimensions:	12- ¹ / ₄ " x 36"
Plant Location(s):	Frederick, Joplin, Tuscaloosa
Fastening Pattern:	<p>For slopes of 2:12 up to 21:12</p> 
Fastening Pattern:	<p>For slopes greater than 21:12</p> 

Table 4 – Heritage

Dimensions:	12" x 36 ^{-3/8} "
Plant Location(s):	Frederick
Fastening Pattern:	<p>For slopes of 2:12 up to 21:12</p>
Fastening Pattern:	<p>For slopes greater than 21:12</p>
Dimensions:	13 ^{-1/4} " x 39 ^{-3/8} "
Plant Location(s):	Dallas, Frederick, Joplin, Phillipsburg, Tuscaloosa
Fastening Pattern:	<p>For slopes of 2:12 up to 21:12</p>
Fastening Pattern:	<p>For slopes greater than 21:12</p>

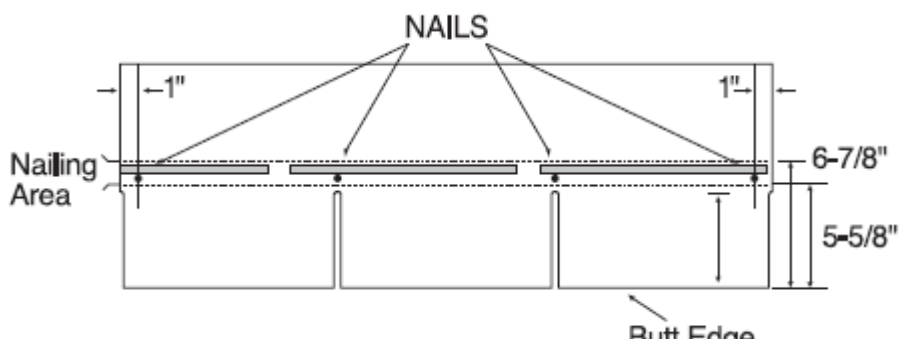
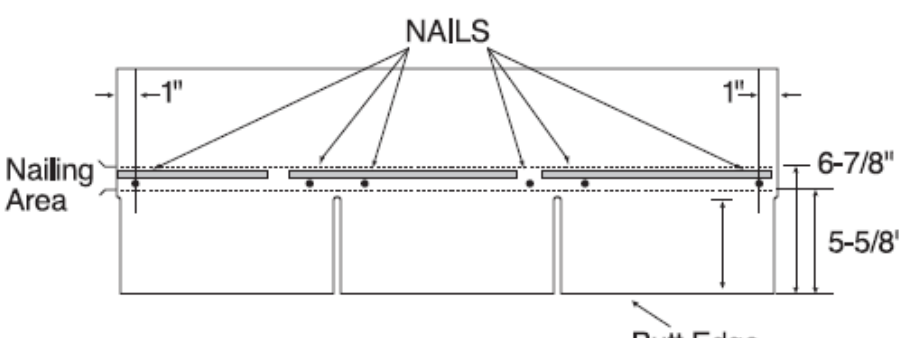
Table 5 – Heritage Premium

Dimensions:	12" x 36"
Plant Location(s):	Frederick
Fastening Pattern:	<p style="text-align: center;">For slopes of 2:12 up to 21:12</p>
Fastening Pattern:	<p style="text-align: center;">For slopes greater than 21:12</p>
Dimensions:	13- ¹ / ₄ " x 39- ³ / ₈ "
Plant Location(s):	Dallas, Phillipsburg, Tuscaloosa, Frederick
Fastening Pattern:	<p style="text-align: center;">For slopes of 2:12 up to 21:12</p>
Fastening Pattern:	<p style="text-align: center;">For slopes greater than 21:12</p>

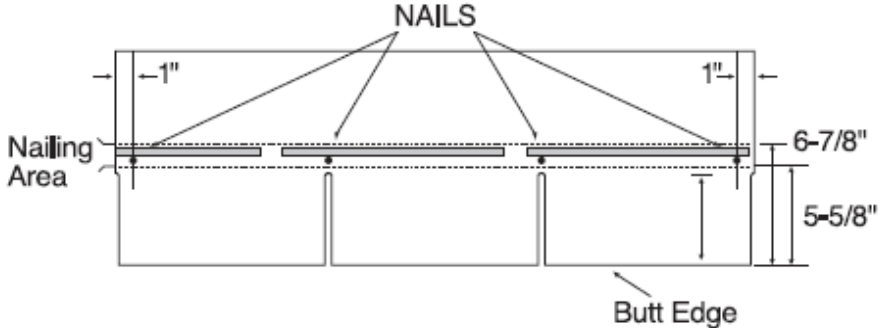
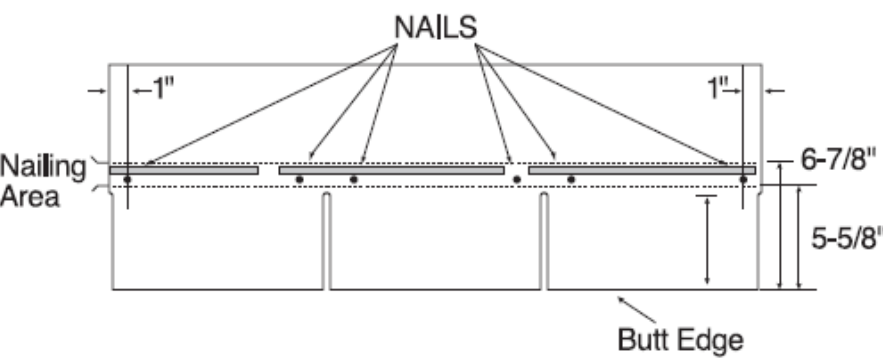
Table 6 – Heritage Woodgate

<p>Dimensions:</p>	<p>12" x 36^{-3/8}"</p>
<p>Plant Location(s):</p>	<p>Frederick</p>
<p>Fastening Pattern:</p>	<p>For slopes of 2:12 up to 21:12</p>  <p>FASTENERS</p> <p>NAIL ZONE/ COMMON BOND</p> <p>5-1/2"</p> <p>EXPOSURE 5"</p> <p>1" 11" 12-3/8" 11" 1"</p>
<p>Fastening Pattern:</p>	<p>For slopes greater than 21:12</p>  <p>FASTENERS</p> <p>NAIL ZONE/ COMMON BOND</p> <p>5-1/2"</p> <p>EXPOSURE 5"</p> <p>1" 9-1/2" 3" 9-3/8" 3" 9-1/2" 1"</p>
<p>Dimensions:</p>	<p>13^{-1/4}" x 39^{-3/8}"</p>
<p>Plant Location(s):</p>	<p>Dallas, Frederick</p>
<p>Fastening Pattern:</p>	<p>For slopes of 2:12 up to 21:12</p>  <p>FASTENERS</p> <p>NAIL ZONE/ COMMON BOND</p> <p>6-1/8"</p> <p>EXPOSURE 5-5/8"</p> <p>1" 12-1/2" 12-3/8" 12-1/2" 1"</p>
<p>Fastening Pattern:</p>	<p>For slopes greater than 21:12</p>  <p>FASTENERS</p> <p>NAIL ZONE/ COMMON BOND</p> <p>6-1/8"</p> <p>EXPOSURE 5 5/8"</p> <p>1" 7-1/2" 7-1/2" 7-3/8" 7-1/2" 7-1/2" 1"</p>

Table 7 – Heritage Vintage

<p>Dimensions:</p>	<p>17-1/2" x 40"</p>
<p>Plant Location(s):</p>	<p>Phillipsburg</p>
<p>Fastening Pattern:</p>	<p>For slopes of 2:12 up to 21:12</p>
<p>Fastening Pattern:</p>	<p>For slopes greater than 21:12</p> <p>Apply under each tab 1" diameter asphalt adhesive cement.</p>

Table 8 – Heritage Vantage 12 X 12 Hip and Ridge

Dimensions:	12" x 12"
Plant Location(s):	Phillipsburg
Fastening Pattern:	

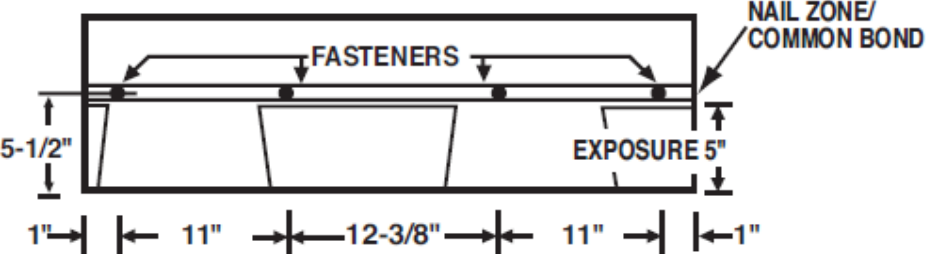
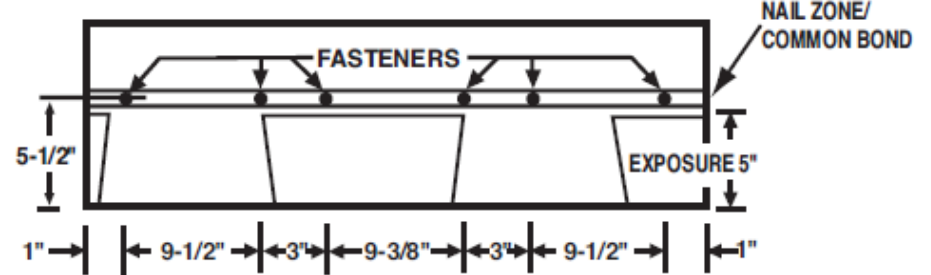
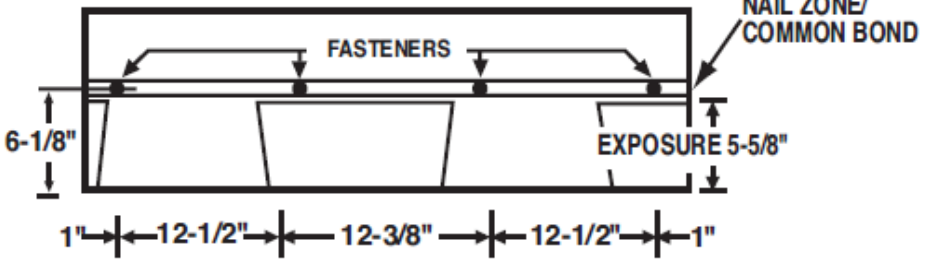
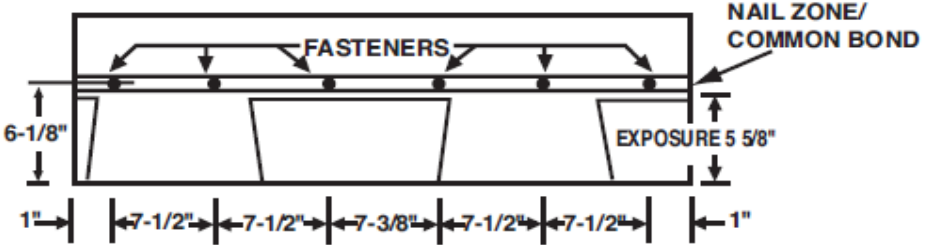
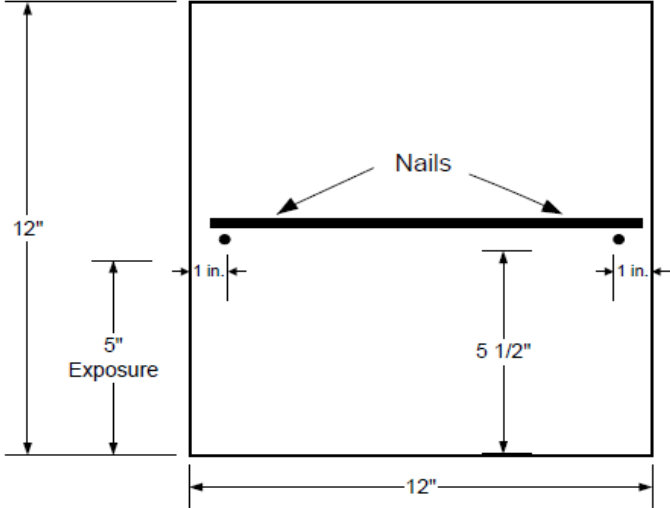
Table 9 – 12-¹/₄ X 12 Hip and Ridge

<p>Dimensions:</p>	<p>12-¹/₄" x 12"</p>
<p>Plant Location(s):</p>	<p>Frederick, Joplin</p>
<p>Fastening Pattern:</p>	<p>The diagram illustrates the fastening pattern for a 12-¹/₄ x 12 hip and ridge. It shows a rectangular area with a horizontal line representing the ridge. Two nails are shown on the ridge, each 1 inch from the edge. The distance from the top edge to the top of the ridge is 5 ¹/₈ inches, labeled as "Exposure". The distance from the bottom edge to the top of the ridge is 5 ⁵/₈ inches. The total width of the area is 12 inches.</p>

© 2017 UL LLC

This UL Evaluation Report is not an endorsement or recommendation for use of the subject and/or product described herein. This report is not the UL Listing or UL Classification Report that covers the subject product. The subject product's UL Listing or UL Classification is covered under a separate UL Report. UL disclaims all representations and warranties whether express or implied, with respect to this report and the subject or product described herein. Contents of this report may be based on data that has been generated by laboratories other than UL that are accredited as complying with ISO/IEC Standard 17025 by the International Accreditation Service (IAS) or by any other accreditation body that is a signatory to the International Laboratory Accreditation Cooperation (ILAC) Mutual Recognition Arrangement (MRA). The scope of the laboratory's accreditation shall include the specific type of testing covered in the test report. As the accuracy of any non-UL data is the responsibility of the accredited laboratory, UL does not accept responsibility for the accuracy of this data.