

UL Solutions Evaluation Report

UL ER2919-02

Issued: April 25, 2014

Revised: November 29, 2023

Visit the UL Solutions [Product iQ® database](#) for current status of report.

UL Category Code: ULEZ

CSI MasterFormat®

DIVISION: 07 00 00 – THERMAL AND MOISTURE PROTECTION
Sub-level 2: 07 30 00 – Steep Slope Roofing
Sub-level 3: 07 31 00 – Shingles and Shakes
Sub-level 4: 07 31 13 – Asphalt Shingle

COMPANY:

TAMKO BUILDING PRODUCTS LLC
198 FOUR STATES DRIVE
GALENA, KANSAS 66739
(417) 624-6644
www.tamko.com

1. SUBJECT: Asphalt Shingles

ELITE GLASS-SEAL

HERITAGE, HERITAGE IR, HERITAGE PREMIUM, HERITAGE WOODGATE, HERITAGE VINTAGE, HERITAGE PROLINE STORMFIGHTER IR, HERITAGE PROLINE TITAN XT, STORMFIGHTER FLEX 3, AND STORMFIGHTER FLEX 4

HERITAGE VINTAGE 12 X 12 HIP AND RIDGE, 12-¼ X 12 HIP AND RIDGE, 12-¼ X 12 HERITAGE HIP AND RIDGE IR, AND PROLINE 12-¼ X 12 HIP AND RIDGE

HERITAGE VINTAGE STARTER, TAMKO 10-INCH STARTER, TAMKO PERFORATED STARTER, TAMKO SHINGLE STARTER

UL Solutions
333 Pflingsten Road
Northbrook, IL 60062
USA

T +1.847.272.8800

UL.com/Solutions

2. SCOPE OF EVALUATION

- 2021, 2018, 2015, and 2012 *International Building Code*® (IBC)
- 2021, 2018, 2015, and 2012 *International Residential Code*® (IRC)
- 2023 Florida Building Code – Building
- 2023 Florida Building Code – Residential
- ICC ES Acceptance Criteria for Quality Documentation (AC10)
- ICC ES Acceptance Criteria for Alternative Asphalt Roofing Shingles (AC438)

The products underwent evaluation for the following properties:

- Exterior Fire Exposure (UL 790)
- Wind Resistance (ASTM D3161; ASTM D7158)
- Physical Properties (ASTM D3462, AC438)
- Impact Resistance (UL 2218)

3. REFERENCED DOCUMENTS

- UL 790, Standard Test Methods for Fire Tests of Roof Coverings
- UL 2218, Standard Test Methods for Impact Resistance of Prepared Roof Covering Materials
- ASTM D3161, Standard Test Method for Wind-Resistance of Asphalt Shingles (Fan-Induced Method)
- ASTM D7158, Standard Test Method for Wind Resistance of Asphalt Shingles (Uplift Force/Uplift Resistance Method)
- UL Subject 2375 Issue No. 2, Outline of Investigation for Hip and Ridge Shingles (UL Fire and Wind Tests)
- ICC ES Acceptance Criteria for Alternative Asphalt Roofing Shingles (AC438)
- ICC ES Acceptance Criteria for Quality Documentation (AC10)

4. USES

TAMKO asphalt shingles described in this report are alternatives to asphalt shingles complying with Section 1507.2.4 of the 2021 and 2018 IBC, Section 1507.2.5 of the 2015, and 2012 IBC, Section 1507.2.5 of the 2023 Florida Building Code - Building, or Section R905.2.4 of the IRC and 2023 Florida Building Code - Residential, and are Class A roof coverings for new and existing roofs.

5. PRODUCT DESCRIPTION

5.1 General:

TAMKO asphalt shingles are roof covering materials complying with the following properties when installed as described in this report. The products are three-tab shingles, laminated shingles, starter shingles, and hip and ridge shingles.

Fire Classification: TAMKO asphalt shingles covered under this Report have been tested for fire classification Class A in accordance with UL 790 . Shingles tested in accordance with UL790 qualify for use under Section 1505.1 of the 2023 Florida Building Code - Building, IBC, -Section R902.1 of the IRC and 2023 Florida Building Code - Residential.

Wind Resistance: TAMKO asphalt shingles covered under this Report have been tested for wind resistance in accordance with ASTM D3161 or ASTM D7158.

Shingles tested in accordance with ASTM D3161 are classified as Class F and qualify for use under the exception to Section 1504.2 of the 2021 IBC, Section 1504.1.1 of the 2018 and 2015 IBC, Section 1507.2.7.1 of the 2012 IBC and 2023 Florida Building Code - Building, the exception to Section R905.2.4.1 of the IRC, and Section R905.2.6.1 of 2023 Florida Building Code – Residential.

Shingles tested in accordance with ASTM D7158 are classified as Class H and qualify for use in locations as shown in Table 1504.2 of the 2021 IBC, Table 1504.1.1 of 2018 and 2015 IBC, Table 1507.2.7.1 of the 2012 IBC and 2023 Florida Building Code - Building, Table R905.2.4.1 of the IRC, or Table R905.2.6.1 of the 2023 Florida Building Code - Residential, where the maximum basic wind speed is 150 mph (67 m/s) or less with exposure category of B or C (ASCE 7) and a maximum building height of 60 feet (18.3 m). Installation must be in accordance with Section 1507.2 of the 2021 and 2018 IBC, 2023 Florida Building Code – Building, and Section 1507.2.7 of the 2015, and 2012 IBC, or Section R905.2 of the IRC and 2023 Florida Building Code - Residential, as applicable.

Physical Properties: TAMKO asphalt shingles covered under this Report have been tested for physical properties in accordance with ICC ES AC438. Shingles tested in accordance with ICC ES AC438 qualify as an alternative roof covering for use under Section 1507.2.4 of the 2021 and 2018 IBC, Section 1507.2.5 of the 2015 and 2012 IBC, Section 1507.2.5 of the 2015 and 2012 IBC and 2023 Florida Building Code - Building, or Section R905.2.4 of the IRC and 2023 Florida Building Code - Residential. When installed on new construction in accordance with this report and the TAMKO Building Products LLC installation instructions, the shingles are a Class A roof covering. When the shingles are installed over existing roof coverings, the Class A fire classification is maintained.

5.2 Three-Tab Shingles – Elite Glass-Seal:

Elite Glass-Seal shingles are three-tab shingles manufactured with a single fiberglass mat, coated on both sides with asphalt, and surfaced on the weather-exposed side with mineral granules. The shingles are self-sealing and have beads of thermal-tab sealing adhesive above the shingle butt on the weather side. See [Table 2](#) for product dimensions and manufacturing locations.

5.3 Laminated Shingles – Heritage, Heritage IR, Heritage Premium, Heritage Woodgate, Heritage Vintage, Heritage Proline Stormfighter IR, and Heritage Proline Titan XT, Stormfighter Flex 3, and Stormfighter Flex 4:

Heritage, Heritage IR, Heritage Premium, Heritage Woodgate, Heritage Vintage, Heritage Proline Stormfighter IR, Heritage Proline Titan XT, and Stormfighter Flex 3, and Stormfighter Flex 4 shingles are laminated shingles manufactured with a double layer of fiberglass mats coated with asphalt on all sides, and surfaced on the weather-exposed side with mineral granules. See [Table 3](#), [Table 4](#), [Table 5](#), [Table 6](#), [Table 7](#), [Table 10](#), [Table 13](#), [Table 13A](#), and [Table 17](#) for product dimensions and manufacturing locations.

5.4 Hip & Ridge Shingles – 12-¼ X 12 Hip and Ridge, Heritage Vintage 12 X 12 Hip and Ridge, 12-¼ X 12 Heritage Hip and Ridge IR, and Proline 12-¼ X 12 Hip and Ridge:

12-¼ X 12 Hip and Ridge, Heritage Vintage 12 X 12 Hip and Ridge, and 12-¼ x 12 Heritage Hip and Ridge IR, and Proline 12-1/4 X 12 Hip and Ridge shingles are prefabricated hip and ridge shingles. Heritage Vintage 12 X 12 Hip and Ridge shingles are perforated so they can be torn into three 12-inch by 12-inch shingles. The 12-¼ X 12 Hip and Ridge and 12-¼ X 12 Heritage Hip and Ridge IR shingles are perforated so they can be torn into three 12-¼ inch by 12-inch shingles. As an alternative, Elite Glass-Seal shingles are cut into three 12-¼ inch by 12-inch hip and ridge shingles. See [Table 8](#), [Table 9](#), and [Table 11](#) for product dimensions and manufacturing locations.

6. INSTALLATION

6.1 General:

TAMKO asphalt shingles must be installed in accordance with the applicable code, this report and the manufacturer's published installation instructions. The shingles must be installed in accordance with Section 1507.2 of the IBC and 2023 Florida Building Code - Building, or Section R905.2 of the IRC and 2023 Florida Building Code - Residential, as applicable, except as noted in this report.

The manufacturer's published installation instructions must be available at all times on the jobsite during installation.

Minimum roof slopes must be 2:12 (16.67% slope) for the three-tab shingles described under 5.1 of this Report and for the laminated shingles described under 5.2 of this Report.

6.2 Underlayment and Ice Barriers:

For roof slopes 4:12 and greater, the roof deck must be covered with a minimum of one layer of underlayment as described in Sections 7.2 and 7.3 of this Report. Underlayment application must be in accordance with Table 1507.1.1 of the 2021 and 2018 IBC, 2023 Florida Building Code - Building, and Section 1507.2.8 of the 2015 and 2012 IBC or Table R905.1.1(2) of the 2021 IRC, Section R905.2.7 of the 2018, 2015, and 2012 IRC, and Section 905.2.3 of the 2023 Florida Building Code - Residential, as applicable.

For roof slopes 2:12 and up to but less than 4:12, two layers of the underlayment described in Section 7.2 or one layer of the self-adhering polymer modified bitumen sheet in described in Section 7.3 of this Report are required. Underlayment application must be in accordance with Section 1507.1.1 of the 2021 and 2018 IBC, 2023 Florida Building Code - Building, and Section 1507.2.8 of the 2015 and 2012 IBC, Section R905.1.1 of the IRC, and 2023 Florida Building Code - Residential, as applicable.

In areas where there has been a history of ice forming along the eaves, causing a backup of water, an ice barrier must be provided in accordance with Section 1507.1.2 of the 2021 and 2018 IBC and Section 1507.2.8.2 of the 2023 Florida Building Code - Building, 2015 and 2012 IBC or Section R905.1.2 of the 2021 and 2018 IRC, 2023 Florida Building Code - Residential, Section R905.16.4.1 of the 2015 IRC, and Section R905.2.7.1 of the 2012 IRC, as applicable.

6.3 Starter Shingle:

A starter course, as described in Section 7.4 of this Report, must be attached to the eave edge using fasteners described in Section 7.5 of this Report, located 1-½ to 3 inches (38.1 to 76.2 mm) from the eave edge and spaced 1 inch (25.4 mm) and 12 inches (305 mm) from each end, for a total of four fasteners per shingle. Starter strips must overhang the eave and rake edges ¼ to ¾ inch (6.4 to 19.1 mm) if no drip edge flashing is present. If drip edge flashing is present, install shingles even with the drip edge or overhang the drip edge up to ¾ inch.

6.4 Asphalt Shingles:

The first course of field shingles must be installed over the starter course described in Section 7.4 of this Report.

Shingles must be installed with vertical joints offset a minimum of 4 inches (102 mm) from adjacent courses.

6.4.1 Three-Tab Shingles – Elite Glass-Seal:

For roof slopes 2:12 up to but less than 21:12 (16.67% to 175% slope), each shingle must be fastened to the roof deck using a minimum of four fasteners, spaced as shown in Table 2 and Table 3.

For roof slopes equal to or greater than 21:12 (175% slope), six fasteners must be used, spaced as shown in Table 2.

Fasteners must be in a nail area between 5-⁵/₈ inches (143 mm) and 6-⁷/₈ inches (175 mm) from the butt edge of the shingle.

Maximum exposure to the weather must be 5-¹/₈ inches (130 mm).

In colder climates or wind regions where it is questionable whether the thermal-sealing adhesive will activate to seal the shingles, the shingles can be hand-sealed. A 1-in diameter (25.4 mm) spot of asphalt cement complying with ASTM D4586, Type I, Class I, should be placed under the corner of each tab (two spots per tab).

6.4.2 Laminated Shingles – Heritage, Heritage IR, Heritage Premium, Heritage Woodgate, Heritage Proline Stormfighter IR, Heritage Proline Titan XT, StormFighter Flex 3 and StormFighter Flex 4:

For roof slopes 2:12 up to but less than 21:12 (16.67% to 175% slope), each shingle must be fastened to the roof deck using a minimum of four fasteners, spaced as shown in Tables 3, 4, 5, 6, 10, 13, and 13A.

For roof slopes over 21:12 (175% slope), six fasteners must be used, spaced as shown in Tables 3, 4, 5, 6, 10, 13, 13A, and 17.

Maximum exposure to the weather must be 5-⁵/₈ inches (143 mm).

In colder climates or wind regions where it is questionable whether the thermal-sealing adhesive will activate to seal the shingles, the shingles can be hand-sealed. Four evenly spaced 1-inch diameter (25.4 mm) spots of cement should be placed under the exposed portion of the shingle, approximately 1 inch (76 mm) above the butt edge.

6.4.3 Laminated Shingles – Heritage Vintage:

For roof slopes 2:12 up to but less than 21:12 (16.67% to 175% slope), each shingle must be fastened to the roof deck using a minimum of five fasteners, spaced as shown in Table 7.

For roof slopes equal to or greater than 21:12 (175% slope), nine fasteners must be used, spaced as shown in Table 7.

Fasteners must be located 6 and 11-¹/₂ inches (152 and 292 mm) above the butt edge of the shingles.

Maximum exposure to the weather must be 5 inches (127 mm).

In colder climates or wind regions where it is questionable whether the thermal-sealing adhesive will activate to seal the shingles, the shingles must be hand-sealed. Four evenly spaced 1-inch diameter (25.4 mm) spots of cement should be placed under the exposed portion of the shingle, approximately 1 inch (127 mm) above the butt edge.

6.5 Valley Construction and Other Flashing:

Valleys must consist of woven, open valley or closed-cut construction and must be flashed in accordance with Section 1507.2.8.2 of the 2021 and 2018 IBC, and Section 1507.2.9.2 of the 2023 Florida Building Code - Building, 2015 and 2012 IBC or Section R905.2.8.2 of the IRC and 2023 Florida Building Code - Residential. Other flashings must be in accordance with Sections 1503.2 1507.2.8 of 2020 Florida Building Code - Building, 2021 and 2018 IBC, and 1507.2.9 of 2023 Florida Building Code – Building, Section 1507.2.9 of the 2015 and 2012 IBC, or Section R905.2.8 of the IRC and 2023 Florida Building Code - Residential, as applicable.

6.6 Hip and Ridge Application:

Hip and ridge shingles must be placed evenly over hips and ridges, and must be fastened to the roof deck using two fasteners, one located on either side of the shingle, 5-¹/₂ inches (140 mm) or 5-⁵/₈ inches (143 mm) from the exposed end, and 1 inch (25.4 mm) in from the edge as shown in Tables 8, 9, and 11. Fasteners must be a minimum ¹/₄ inch (6.4 mm) longer than those used in the field of the roof, as specified in Section 7.5 of this report. The 12-¹/₄ X 12 Hip and Ridge and 12-¹/₄ x 12 Heritage Hip and Ridge IR, and Proline 12-¹/₄ X 12 Hip and Ridge prefabricated hip and ridge shingles must be installed with a maximum exposure of 5-¹/₈ in. (130 mm). Heritage Vintage 12 X 12 Hip and Ridge prefabricated hip and ridge shingles must be installed with a maximum exposure of 5 in. (127 mm). Hip and ridge shingles are installed starting at the bottom of the hip or from the end of the ridge opposite the direction of the prevailing wind.

6.7 Reroofing:

The existing asphalt shingle roof covering must be inspected in accordance with the provisions and limitations of Section 1512 of the 2021 IBC, Section 1511 of the 2018, 2015 IBC, and Section 1510 of the 2012 IBC Section 1511.1 of the 2023 Florida Building Code - Building, Section R908 of the IRC, or Section 908 of the 2023 Florida Building Code -Residential, as applicable. Prior to the reroofing, hip and ridge coverings must be removed.

Except as noted in this section, the shingles must be installed in accordance with Section 6.3 and 6.5 of this Report. Fasteners must be of sufficient length to penetrate ³/₄ inch (19.1 mm) into the sheathing, or through the sheathing where the sheathing is less than ³/₄ inch (19.1 mm) thick. Flashing and edging must comply with Section 6.4 and with Section 1512.5 of the 2021 IBC, 1511.6 of the 2018 and 2015 IBC and 2023 Florida Building Code - Building, Section 1510.6 of the 2012 IBC and Section R908.6 of the 2018 and 2015 IRC, 2023 Florida Building Code - Residential, and R907.6 of the 2012 IRC, as applicable.

7. INSTALLATION MATERIALS

7.1 Sheathing:

The roof deck must be code-complying, minimum ³/₈-inch thick (9.5 mm), exterior plywood complying with DOC PS-1; rated sheathing complying with DOC PS-2; or solid sheathing using minimum nominally 1 by 6 lumber.

7.2 Underlayment:

Under the IBC or IRC, underlayment must comply with ASTM D226, Type I (minimum), ASTM D4869, Type I (minimum) , ASTM D1970, or ASTM D6757 as specified in Section 1507.2.3 of the IBC or Section 905.1.1 of the IRC. Under the 2023 Florida Building Code – Building, underlayment must comply with ASTM D226, ASTM D4869, ASTM D1970, ASTM D6757, or ASTM D8257 as specified in Section 1507.1.1 Under the IRC and 2023 Florida Building Code – Residential, underlayment must comply with ASTM D226, Type I (minimum), ASTM D4869, Type I (minimum), ASTM D1970, ASTM D6757, or ASTM D8257 as specified in Section R905.1.1.

7.3 Self-adhering Polymer Modified Bitumen Sheet:

The self-adhering polymer modified bitumen sheet must comply with ASTM D1970.

7.4 Starter Shingles:

The starter course shingle consists of either TAMKO 10-inch starter, TAMKO Shingle Starter, TAMKO Perforated Starter, or a self-sealing three-tab shingle. If self-sealing three-tab shingles are used, remove the exposed tab portion and install with factory-applied sealant adjacent to the eaves.

Heritage Vintage requires a Heritage Vintage starter shown in Table 12 is to be installed over the starter course at the eave edge.

TAMKO Shingles require a TAMKO Shingle Starter as shown as in Table 14, Table 15, or Table 16 which must be installed over the starter course at the eave edge.

7.5 Fasteners:

Fasteners must be minimum No. 12 gage [0.105 inch (2.7 mm)], 3/8-inch diameter head (9.5 mm), galvanized, stainless steel, aluminum or copper corrosion-resistance nails. Fasteners must be of sufficient length to penetrate into the sheathing 3/4-inch (19.1 mm), or through the sheathing, where the sheathing is less than 3/4-inch (19.1 mm) thick. Fasteners must be compliant with ASTM F1667.

7.6 Asphalt Cement:

Asphalt cement must comply with ASTM D 4586, Type I, Class I.

8. CONDITIONS OF USE

8.1 General:

The TAMKO Asphalt Shingles described in this Report comply with, or are suitable alternatives to, what is specified in those codes listed in Section 2 of this Report, subject to the following conditions:

- 8.2** Materials and methods of installation shall comply with this Report and the manufacturer's published installation instructions. In the event of a conflict between the installation instructions and this Report, this Report governs.
- 8.3** See UL [Product iQ™ database](#) for Prepared Roof-Covering Materials evaluated for exterior fire exposure in accordance with UL 790 Standard Test Methods for Fire Tests of Roof Coverings ([TFWZ](#)).
- 8.4** The products listed in Table 1 of this Report are manufactured by TAMKO Building Products, located at the manufacturing locations named below, under the UL LLC Classification and Follow-Up Service Program, which includes inspections in accordance with the quality elements of ICC-ES Acceptance Criteria for Quality Documentation, AC 10.

Table 1 – Manufacturing Locations

Location	Plant ID (if applicable)
7910 S CENTRAL EXPY DALLAS TX 75216	D
4500 TAMKO DR FREDERICK MD 21704	F
601 N HIGH ST JOPLIN MO 64801	J
1598 HWY 183 PHILLIPSBURG KS 67661	P
KAUL INDUSTRIAL PARK 2300 35TH ST TUSCALOOSA AL 35401	T

9. SUPPORTING EVIDENCE

- 9.1** Manufacturer’s descriptive product literature, including installation instructions.
- 9.2** See UL [Product iQ™ database](#) for the following:
- 9.2.1** UL test reports and Classification in accordance with UL 790, Class A and UL Subject 2375 for Roof-Covering Materials ([TFWZ](#)).
 - 9.2.2** UL test reports and Classification in accordance with ASTM D3462 for Prepared Roof- Covering Materials ([TFWZ](#)).
 - 9.2.3** UL test reports and Classification in accordance with ASTM D7158, Class H for Prepared Roof-Covering Materials ([TGAH](#)).
 - 9.2.4** UL test reports and Classification in accordance with ASTM D3161, Class F Prepared Roof-Covering Materials ([TFWZ](#)).
 - 9.2.5** UL test reports and Classification in accordance with UL 2218 Roof-covering Materials, Impact Resistance ([TGAM](#)).
- 9.3** Quality Documentation in accordance with ICC-ES Acceptance Criteria for Quality Documentation, AC10.

10. IDENTIFICATION

The TAMKO asphalt shingles described in this evaluation report are identified by a marking bearing the report holder’s name, TAMKO Building Products LLC, the plant identification, the product name, the UL Solutions Classification Mark, and the evaluation report number UL Solutions ER2919-02. The validity of this evaluation report is contingent upon this identification appearing on the product or UL Solutions Classification Mark certificate.

11. USE OF UL SOLUTIONS EVALUATION REPORT

- 11.1** The approval of building products, materials or systems is under the responsibility of the applicable authorities.
- 11.2** UL Solutions Evaluation Reports shall not be used in any manner that implies an endorsement of the product, material or system by UL Solutions.
- 11.3** The current status of this report, as well as a complete directory of UL Solutions Evaluation Reports, may be found at UL.com/Solutions via Product iQ®.

Table 2 – Elite Glass-Seal

<p>Dimensions:</p>	<p>12-¼" x 36"</p>
<p>Plant Location(s):</p>	<p>Frederick, Joplin</p>
<p>Fastening Pattern:</p>	<p>For slopes 2:12 up to but less than 21:12</p> 
<p>Fastening Pattern:</p>	<p>For slopes equal to or greater than 21:12</p> 

Table 3 – Heritage

<p>Dimensions:</p>	<p>13-¹/₄" x 39-³/₈"</p>
<p>Plant Location(s):</p>	<p>Dallas, Frederick, Joplin, Phillipsburg</p>
<p>Fastening Pattern:</p>	<p>For slopes between 2:12 up to but less than 21:12</p> 
<p>Fastening Pattern:</p>	<p>For slopes equal to or greater than 21:12</p> 

Table 4 – Heritage

<p>Dimensions:</p>	<p>13-1/4" x 39-3/8"</p>
<p>Plant Location(s):</p>	<p>Tuscaloosa</p>
<p>Fastening Pattern:</p>	<p>For slopes between 2:12 up to but less than 21:12</p> <p>For slopes equal to or greater than 21:12</p>
<p>Fastening Pattern:</p>	<p>For slopes equal to or greater than 21:12</p>

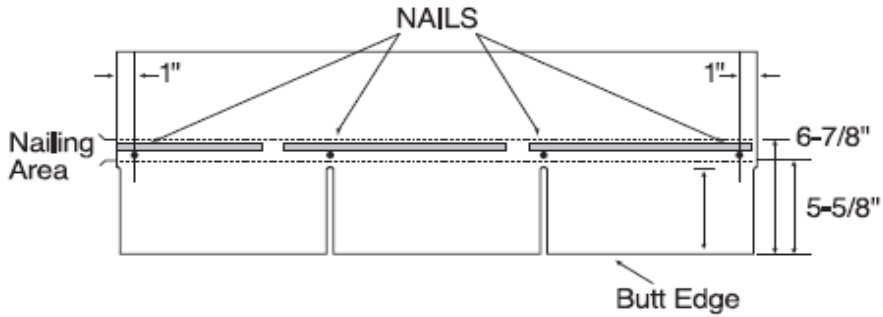
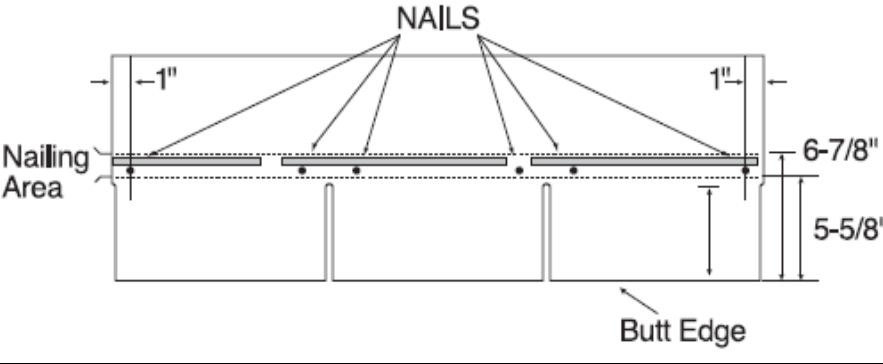
Table 5 – Heritage Premium

Dimensions:	13-¼" x 39-³⁄₈"
Plant Location(s):	Phillipsburg, Frederick
Fastening Pattern:	<p>For slopes between 2:12 up to but less than 21:12</p>
Fastening Pattern:	<p>For slopes equal to or greater than 21:12</p>

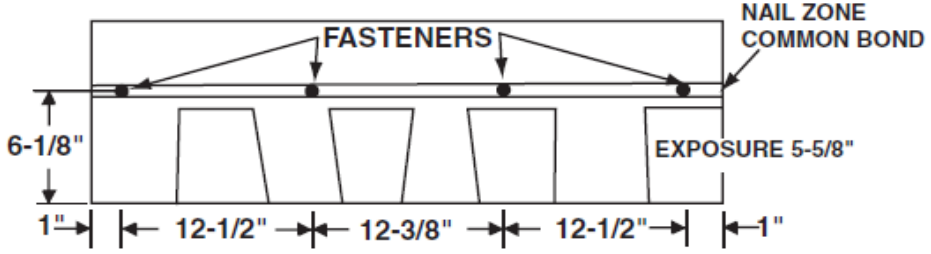
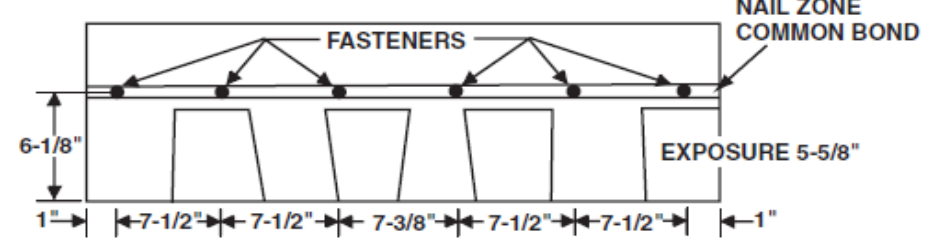
Table 6 – Heritage Woodgate

Dimensions:	13-¼" x 39-³⁄₈"
Plant Location(s):	Dallas, Frederick
Fastening Pattern:	<p>For slopes of 2:12 up to but less than 21:12</p>
Fastening Pattern:	<p>For slopes equal to or greater than 21:12</p>

Table 7 – Heritage Vintage

<p>Dimensions:</p>	<p>17-1/2" x 40"</p>
<p>Plant Location(s):</p>	<p>Phillipsburg</p>
<p>Fastening Pattern:</p>	<p>For slopes between 2:12 up to but less than 21:12</p>
<p>Fastening Pattern:</p>	<p>For slopes equal to or greater than 21:12</p> <p>Apply under each tab 1" diameter asphalt adhesive cement.</p>

Table 8 – Heritage Vintage 12 X 12 Hip and Ridge

<p>Dimensions:</p>	<p>12" x 12"</p>
<p>Plant Location(s):</p>	<p>Phillipsburg</p>
<p>Fastening Pattern:</p>	<p>The diagram illustrates the fastening pattern for a 12" x 12" hip and ridge. It shows a square with a horizontal line across the top. Two nails are indicated by dots on this line, with arrows pointing to them labeled "Nails". Dimensions include a total height of 12 inches, a 5-inch exposure from the bottom edge to the top line, a 5 1/2 inch distance between the nails, and 1 inch from each nail to the side edges.</p>

Table 9 – 12-1/4 X 12 Hip and Ridge

<p>Dimensions:</p>	<p>12-1/4" x 12"</p>
<p>Plant Location(s):</p>	<p>Frederick, Joplin</p>
<p>Fastening Pattern:</p>	<p>The diagram illustrates the fastening pattern for a 12-1/4" x 12" hip and ridge. It shows a rectangular area with a horizontal line representing the ridge. Two nails are shown on the ridge, each 1 inch from the left and right edges. The distance between the nails is 5 5/8 inches. The total height of the area is 12-1/4 inches, and the total width is 12 inches. The distance from the bottom edge to the ridge line is 5 1/8 inches, labeled as "Exposure".</p>

Table 10 – Heritage IR

<p>Dimensions:</p>	<p>13-¹/₄" x 39-³/₈"</p>
<p>Plant Location(s):</p>	<p>Joplin, Philipsburg</p>
<p>Fastening Pattern:</p>	<p>For slopes between 2:12 up to but less than 21:12</p> 
<p>Fastening Pattern:</p>	<p>For slopes equal to or greater than 21:12</p> 

Table 11 Heritage Hip and Ridge IR, Proline 12-¹/₄ x 12 Hip and Ridge

Dimensions:	12- ¹ / ₄ " x 12"
Plant Location(s):	Joplin
Fastening Pattern:	

Table 12 Heritage Vintage Starter

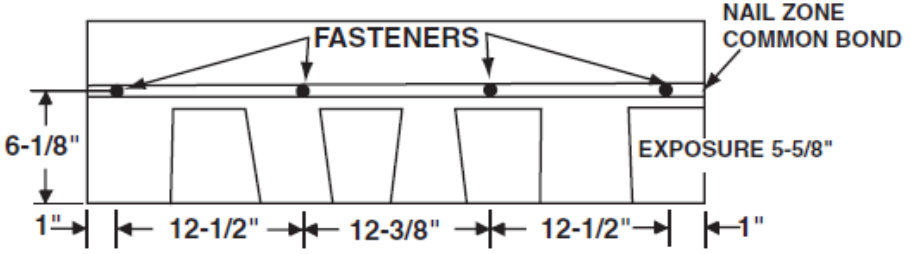
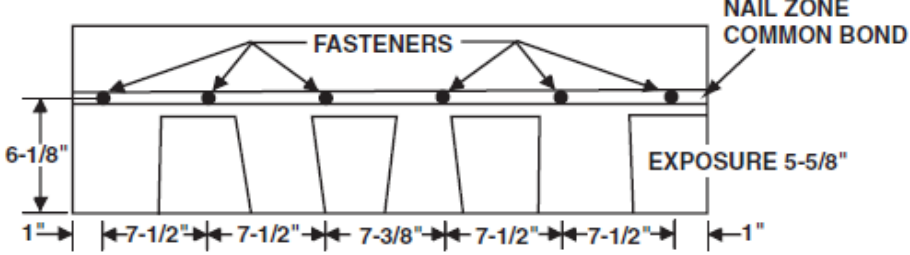
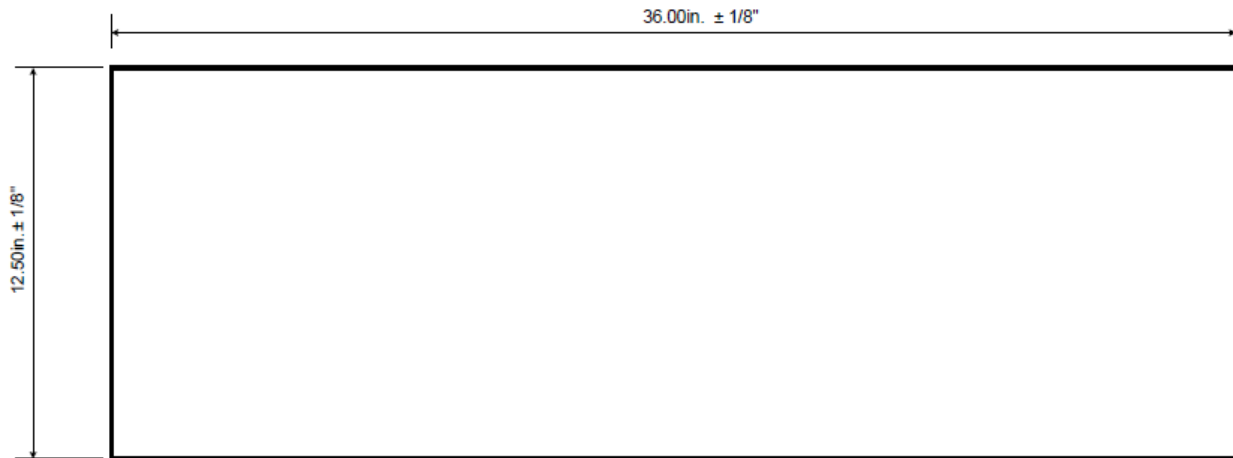

Table 13– Heritage Proline Titan XT

<p>Dimensions:</p>	<p>13-1/4" x 39-3/8"</p>
<p>Plant Location(s):</p>	<p>Frederick, Joplin, Tuscaloosa, Philipsburg, Dallas</p>
<p>Fastening Pattern:</p>	<p>For slopes 2:12 up to but less than 21:12</p>
<p>Fastening Pattern:</p>	<p>For slopes equal to or greater than 21:12</p>

Table 13A– Heritage Proline Stormfighter IR

<p>Dimensions:</p>	<p>13-¹/₄" x 39-³/₈"</p>
<p>Plant Location(s):</p>	<p>Joplin, Philipsburg</p>
<p>Fastening Pattern:</p>	<p>For slopes 2:12 up to but less than 21:12</p>  <p>Preferred Fastener Locations</p> <p>Nail Zone</p> <p>Paint Lines</p> <p>5-5/8" Exposure</p> <p>39-3/8"</p> <p>13-1/4"</p> <p>7-5/8"</p> <p>6-1/8"</p> <p>1"</p> <p>12-1/2"</p> <p>12-3/8"</p> <p>12-1/2"</p> <p>1"</p> <p>Acceptable Fastener Location</p> <p>Preferred Fastener Location</p>
<p>Fastening Pattern:</p>	<p>For slopes equal to or greater than 21:12</p>  <p>Required Fastener Locations</p> <p>Nail Line</p> <p>Paint Lines</p> <p>5-5/8" Exposure</p> <p>39-3/8"</p> <p>13-1/4"</p> <p>6-1/8"</p> <p>1"</p> <p>16"</p> <p>8-1/2"</p> <p>7-3/8"</p> <p>16"</p> <p>8-1/2"</p> <p>1"</p> <p>Required Fastener Location</p>

Table 14– TAMKO 10-Inch Starter

Dimensions:	10" x 40"
Plant Location:	Philipsburg
	<p>For slopes 2:12 up to but less than 21:12</p>

Table 15– TAMKO Perforated Starter

Dimensions:	13-1/4" x 39-3/8"
Plant Location:	Frederick
	<p>For slopes 2:12 up to but less than 21:12</p>

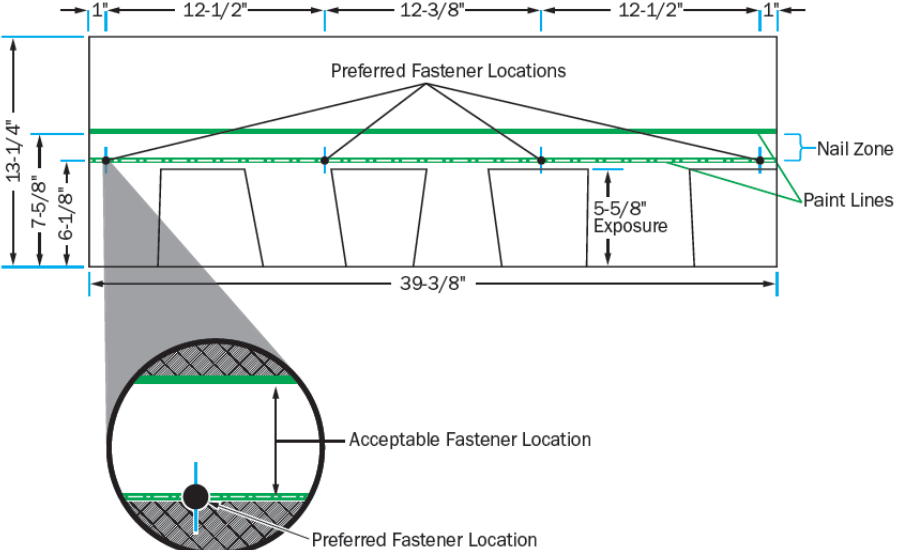
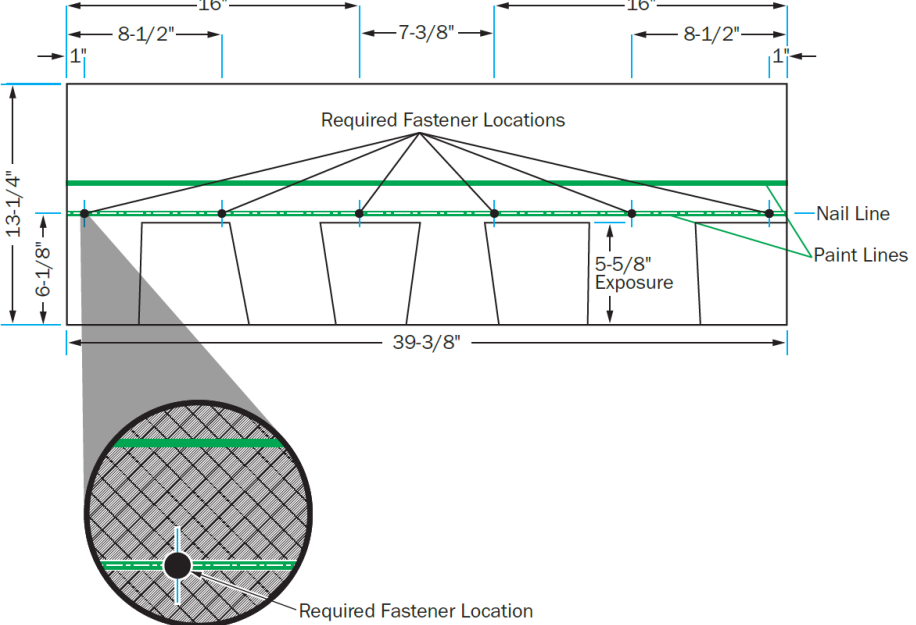
Table 16– TAMKO Shingle Starter

Dimensions:	7" x 36"
Plant Location:	Joplin
	<p>For slopes 2:12 up to but less than 21:12</p>

Table 17– Stormfighter Flex 3, Stormfighter Flex 4

<p>Dimensions:</p>	<p>13-1/4" x 39-3/8"</p>
<p>Plant Location(s):</p>	<p>Frederick, Joplin, Tuscaloosa, Philipsburg, Dallas</p>
<p>Fastening Pattern:</p>	<p style="text-align: center;">For slopes 2:12 up to but less than 21:12</p> <p style="text-align: center;">For slopes equal to or greater than 21:12</p>

UL Solutions Evaluation Reports

© 2023 UL LLC

This UL Solutions Evaluation Report is not an endorsement or recommendation for use of the subject and/or product described herein. This Report is not the UL Solutions Listing or UL Solutions Classification Report that covers the subject product. The subject product's UL Solutions Listing or UL Solutions Classification is covered under a separate UL Solutions Report. UL Solutions disclaims all representations and warranties whether express or implied, with respect to this Report and the subject or product described herein. Contents of this Report may be based on data that has been generated by laboratories other than UL Solutions that are accredited as complying with ISO/IEC Standard 17025 by the International Accreditation Service (IAS) or by any other accreditation body that is a signatory to the International Laboratory Accreditation Cooperation (ILAC) Mutual Recognition Arrangement (MRA). The scope of the laboratory's accreditation shall include the specific type of testing covered in the test Report. As the accuracy of any non-UL Solutions data is the responsibility of the accredited laboratory, UL Solutions does not accept responsibility for the accuracy of this data.

UL Solutions Headquarters
333 Pfingsten Road
Northbrook, IL 60062-2096 USA
T: 847.272.8800
[UL.com/Solutions](https://www.ul.com/Solutions)